

Innovative Hybrid War Strategy Optimization with Incremental Conductance for Maximum Power Point Tracking in Partially Shaded Photovoltaic Systems

Research paper

Hechmi Khaterchi^{*✉}, Chiheb Ben Regaya[✉], Ahmed Jeridi[✉], Abderrahmen Zaafour[✉]

University of Tunis, National Higher School of Engineers of Tunis (ENSIT), Laboratory of Engineering of Industrial Systems and Renewable Energy (LISIER), 1008 Tunis, Tunisia

Received: 18 September 2024; Accepted: 15 November 2024

Abstract: This paper introduces a novel maximum power point tracking (MPPT) controller for photovoltaic (PV) systems that leverages the strengths of both metaheuristic and heuristic methods. Classical MPPT algorithms, such as incremental conductance (IC) and perturb and observe (P&O), are widely used but often struggle with instability, oscillations near the steady state, and slow convergence, particularly under fluctuating weather conditions such as static partial shading conditions (PSCs). To address these challenges, we propose a hybrid MPPT approach that combines the war strategy optimization (WSO) algorithm with the IC method, termed war strategy optimization-incremental conductance (WSO-IC). The performance of the WSO-IC algorithm is rigorously compared against traditional IC, P&O, and standalone WSO techniques. Simulation results validate that the WSO-IC approach provides superior MPPT with faster convergence and high efficiency. The results obtained in SIMULINK demonstrate that the proposed method can achieve efficiencies exceeding 99%, even under static partial shading conditions.

Keywords: photovoltaic system • maximum power point tracking • war strategy optimization • incremental conductance

1. Introduction

Although solar energy can be intermittent, it has become a preferred option due to its low carbon emissions, large-scale production potential, and ability to be integrated into various energy systems. The conversion into electricity is achieved using photovoltaic (PV) systems, which are utilized in various applications, including residential use, water pumping, electric vehicles, and grid-connected configurations (Adel et al., 2019; Alharthi et al., 2021; Khatib and Muhsen, 2020). However, optimizing the energy output from PV systems presents challenges due to the non-linear electrical characteristics (current–voltage) of PV cells, which are influenced by weather conditions such as radiation and temperature. To maximize energy extraction, a maximum power point tracking (MPPT) algorithm is employed to effectively solve this optimization problem.

Numerous studies have addressed the challenge of identifying the optimal operating point to maximize energy extraction from PV modules using different MPPT methods. Among the most widely used are the perturb and observe (P&O) (Manna and Akella, 2021; Salman et al., 2018) and incremental conductance (IC) MPPT controllers (Abd et al., 2019; Shang et al., 2020). These classical methods are simple, easy to implement, and generally effective in tracking the maximum power point (MPP) under normal conditions. However, they suffer from drawbacks such as continuous oscillations around the MPP and slow convergence when there are sudden changes in temperature or

* Email: hechmi.khaterchi@uvt.tn

irradiation, which can lead to a significant power loss during steady-state conditions. Additionally, these classical methods are ineffective in handling the issue of partial shading conditions (PSCs) (Ko et al., 2020).

In recent years, several advanced control methods have been proposed to address the limitations of classical MPPT techniques. These include sliding mode control (SMC)-based MPPT algorithms (Zhang et al., 2022), backstepping controllers (Chennoufi et al., 2021), grey wolf optimization (GWO) (Guo et al., 2020), and various optimization algorithms such as ant colony optimization (ACO) (Priyadarshi et al., 2019), particle swarm optimization based on radial basis function algorithm (PSO-RBF) (Hamdi et al., 2019), flower pollination algorithm (FPA) (De et al., 2021), glow worm swarm optimization (Jin et al., 2017), Cuckoo search algorithm (CSA) (Abo-Elyousr et al., 2020), and artificial bee colony (ABC) (González-Castaño et al., 2021). A particle swarm optimization (PSO)-based MPPT technique is proposed for efficient global maximum power point tracking (GMPP) under partial shading conditions (Brahmi, M. et al., 2022). While these methods have demonstrated improved MPP tracking capabilities, they also introduce increased system complexity and have not fully resolved the challenges caused by partial shading (Ahmed, 2022; Sagonda and Folly, 2022).

All these methods ensure global convergence, but they have major drawbacks such as long response times and low tracking efficiency. Additionally, they require significant computational time and resources to achieve satisfactory results (Ali et al., 2022; Ibrahim et al., 2023) proposed a new modified hybrid particle swarm optimization proportional–integral–derivative (MPSO-PID) with an anti-windup strategy based on MPPT. The results demonstrate the robustness and effectiveness of the proposed strategies in improving the performance of particle swarm optimization (PSO) and PV systems. However, the MPSO-PID hybrid needs to be compared with other optimization algorithms to reduce ripple content and improve the efficiency of the PV installation. In this context, an efficient MPPT method based on a modified version of the hybrid war strategy optimization-incremental conductance (WSO-IC) algorithm is proposed to track the MPP in the PV system. The main contribution of this method is to enhance the hybrid algorithm by utilizing the strengths of the WSO metaheuristic algorithm and the adaptive IC heuristic algorithm to accelerate convergence to the MPP, reduce output power oscillation, and minimize power losses.

Moosavi et al. (2022) proposed a new MPPT control approach for PV systems based on the dynamic group-based cooperation optimization (DGBCO) algorithm. The DGBCO reduces tracking time by up to 60%, achieving a tracking efficiency of 99.86% under both dynamic and steady-state conditions, and provides a 2% to 8% increase in harvested energy compared to other conventional techniques. In our simulations, the WSO-IC method also achieves comparable tracking efficiency, ranging between 99.4% and 99.9%, and offers a similar increase, particularly under PSCs.

In addition, to demonstrate the superiority and robustness of the proposed hybrid WSO-IC, the results obtained are compared with the following conventional MPPT controllers: the classic (P&O) MPPT controller and the original MPPT algorithms (IC and WSO). The contributions of the method presented in this article are summarized as follows: A new MPPT controller based on a hybrid WSO-IC has been proposed, ensuring a faster response time with minimal power losses and minimal oscillation around the MPP. The proposed Maximum Power Point Tracking (MPPT) control algorithm performs more reliably and effectively, even when there are fixed or steady partial shading conditions (PSCs) on the photovoltaic system. Real-time simulation and a comparison study of the proposed MPPT control based on WSO-IC are performed using MATLAB/Simulink.

1.1. Motivation and contributions

The motivation behind the hybridization of WSO and IC lies in overcoming the limitations inherent in each individual algorithm when applied to MPPT in PV systems. The IC algorithm, while effective in precisely tracking the MPP by analysing the local gradient of the power curve, can be slow to converge, especially under static PSCs. Moreover, the IC method exhibits remarkable oscillations around the MPP, which can lead to power loss. Conversely, the WSO algorithm excels in global optimization by exploring a broad search space. However, WSO alone may not provide the necessary precision in converging to the exact MPP due to its reliance on population-based heuristics. By integrating WSO with IC, the hybrid algorithm leverages the global search capability of WSO and the local fine-tuning ability of IC, resulting in a more efficient and robust MPPT solution in static PSCs.

1.2. The novelty

The main novelty of our work lies in the development of a hybrid MPPT controller that combines the strengths of the WSO algorithm with the IC method. While classical MPPT techniques, such as P&O and IC, have proven effective

under normal conditions, they face challenges due to the complexities introduced by partial shading. Our approach addresses these limitations by leveraging the global optimization capabilities of WSO while benefiting from the local tracking precision of IC, resulting in a more robust and effective solution for maximizing energy production in PV systems.

In particular, our hybrid WSO-IC algorithm improves convergence speed toward the MPP while significantly reducing output power oscillations and energy losses, especially under static PSCs. The results indicate impressive tracking efficiency, ranging from 99.4% to 99.9%, demonstrating its superiority over conventional methods. Additionally, we provide real-time simulations using MATLAB/Simulink, comparing our hybrid algorithm with traditional controllers, thus reinforcing the efficiency and robustness of our method. In summary, our contributions include:

1. A new MPPT controller that combines WSO and IC to enhance performance in PSCs.
2. Significant improvements in response time, reduction of power losses, and minimization of oscillations around the MPP.
3. Comprehensive validation through comparative studies with established MPPT techniques, reinforcing the applicability and efficiency of the method in real-world scenarios.

The organization of the article is structured as follows:

- Section 2—The PV Conversion Chain: Description and Modelling: This section covers the modelling of solar cells, static boost converters, and the impact of partial shading on PV systems.
- Section 3—Hybrid WSO-IC Algorithm for MPPT: This section explores the IC and WSO algorithms, introduces the hybrid WSO-IC approach, and discusses its advantages.
- Section 4—Simulation Results and Statistical Analysis: This section presents the simulated outcomes and a comprehensive statistical analysis of the proposed methods.
- Section 5—Conclusion: The concluding section summarizes the main contributions and highlights future research directions.

2. The PV Conversion Chain: Description and Modelling

The MPP is reached by controlling a DC–DC converter using a MPPT controller, as illustrated in Figure 1. The MPPT controller optimizes the transfer of power from the PV installation to the load under different weather conditions.

The PV installation consists of two identical panels connected in series, with their electrical characteristics provided in Table 1.

The electrical parameters of the DC–DC boost converter used in simulation are listed in Table 2.

The components of the boost converter play a critical role in the system's operation and directly influence the performance of the WSO-IC algorithm. The inductance (L) helps reduce the current ripple to ensure a stable

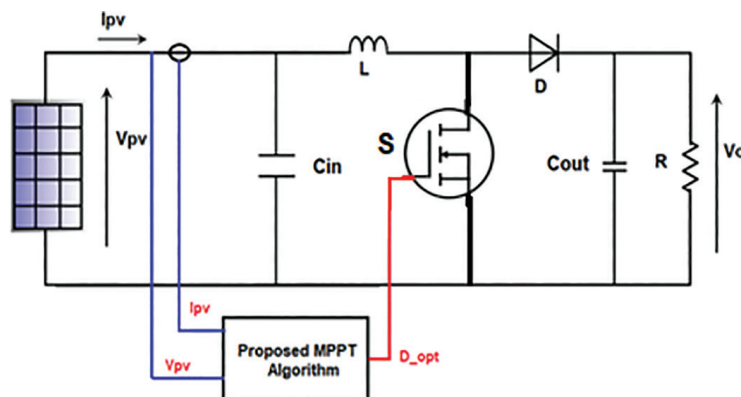

Figure 1. General PV conversion chain. PV, photovoltaic.

Table 1. Electrical specifications of the PV panels.

	Pmax	Voc	Isc	Vmp	Imp
PV module	213.15 W	36.3 V	7.84 A	29 V	7.35 A
PV installation	426.3 W	72.6 V	7.84 A	58 V	7.35 A

Imp, output current at the MPP under STC; Isc, short circuit current under STC; Pmax, maximum power output under STC; PV, photovoltaic; STC, standard test conditions; Vmp, voltage at the MPP under STC; Voc, open circuit voltage under STC.

Table 2. Electrical specifications of the boost converter.

Parameter	Noun	Value
Boost converter		
L	Inductance (mH)	1.1478
C_{in}	Input capacitor (μ F)	6.800
C_{out}	Output capacitor (μ F)	3.300
F	PWM frequency (kHz)	10
Load		
R	Resistive load (Ω)	100

PWM, pulse width modulation.

power supply. The input (C_{in}) and output (C_{out}) capacitors maintain smooth input and output voltages, respectively, minimizing disturbances during the MPPT process. The load resistance (R), set at 100 Ω in our study, simulates system consumption and plays a crucial role in validating the converter's energy efficiency. Additionally, the switching frequency (F), set at 10 kHz, affects the system's responsiveness: a higher frequency enables faster MPPT tracking but may increase switching losses. Optimizing these parameters ensures stable converter operation, which enhances the accuracy and convergence speed of the WSO-IC algorithm, especially under PSCs and rapid irradiance variations.

2.1. Modelling of PV module

A PV cell is described by the single-diode model. This model is generalized to a PV module by considering it as a set of identical cells connected in series and/or in parallel. A model of an elementary cell is constructed based on the most commonly used equivalent electrical circuit, as illustrated in Figure 2 (Drif et al., 2024).

A PV system is made up of several PV modules that are electrically connected in series (N_s) and parallel (N_p) arrangements to enhance the overall power output. The model for a PV system is articulated through the following equations (Manuel and İnanç, 2022):

$$I_{pv} = N_p \cdot I_{ph} - N_p \cdot I_D \left[\exp(\phi) - 1 \right] - \frac{N_s V_{pv} + \frac{N_s}{N_p} R_s I_{pv}}{\frac{N_s}{N_p} R_{sh}} \quad (1)$$

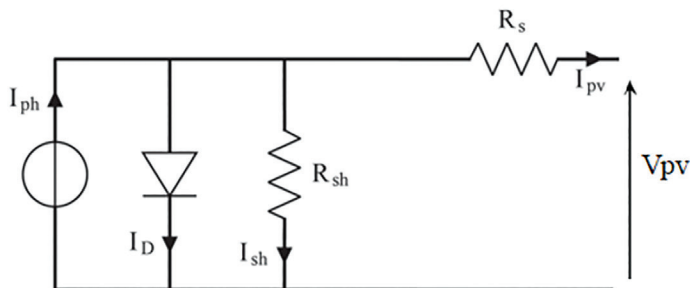
Figure 2. Equivalent circuit diagram of solar cell.

with

$$\phi = \frac{N_s V_{pv} + \frac{N_s}{N_p} R_s I_{pv}}{N_s V_t} \quad (2)$$

$$V_t = \frac{ak_b T}{e} \quad (3)$$

$$I_{ph} = (I_{sc} + k_i (T - 270)) \frac{G}{1000} \quad (4)$$

$$I_D = I_{dr} \left(\frac{T}{298} \right)^3 \exp \left(\frac{qE_g}{N_s k_b V_t} \left(\frac{1}{298} - \frac{1}{T} \right) \right) \quad (5)$$

Several parameters influence the current generated by a solar cell. These include:

- I_{ph} (Photocurrent): The current generated by sunlight hitting the cell.
- I_{sc} (Short-circuit current): The maximum current produced when the cell's output is directly shorted.
- I_D (Dark saturation current): The small leakage current that flows even in darkness.
- I_{dr} (Reference dark saturation current): A reference value for the dark saturation current.
- N_s (Number of series cells): The number of solar cells connected in series within the panel.
- R_s (Series resistance): Internal resistance that reduces the voltage output.
- R_{sh} (Shunt resistance): Leakage path for a small amount of current, typically negligible.
- V_t (Thermal voltage): Voltage related to the cell's temperature.
- q (Electron charge): Fundamental constant representing the charge of an electron ($1.60217646 \times 10^{-19} \text{C}$).
- E_g (Photon energy): Energy of a photon (light particle) that excites electrons in the cell.
- k_i (Short-circuit coefficient): Factor related to the cell's current generation under short-circuit conditions.
- k_b (Boltzmann constant): Fundamental physical constant ($1.3806503 \times 10^{-23} \text{ J/K}$).

2.2. DC–DC boost converter

The DC–DC converter plays a vital role in implementing MPPT within PV systems. MPPT algorithms typically work in tandem with the DC–DC converter to optimize system performance and maximize energy conversion efficiency under fluctuating operating conditions. A boost converter, for instance, is a type of DC–DC converter that increases the output voltage above the input level (Regaya et al., 2020). The power generated by the PV panel is directed to this boost converter, which is regulated by a pulse–width modulation (PWM) signal from the MPPT controller.

The duty cycle (D) of the boost converter is continuously adjusted to optimize the PV system's power output (MPPT) under varying conditions. As noted by Al-Dhaifallah et al. (2018), this adjustment considers different PV system configurations, fluctuating solar irradiation levels, and ambient temperatures. Additionally, an input capacitor is placed on the PV panel side to filter out high-frequency variations in current.

As detailed in previous research (Chroua et al., 2023; Kumar and Gupta, 2012), the optimal duty cycle of the DC–DC boost converter, which makes it possible to extract the maximum power generated by the PVG, is given by the following relationship:

$$D_{mpp} = 1 - \frac{V_{mpp}}{\sqrt{P_{mpp} \times R_{load}}} \quad (6)$$

P_{mpp} : Maximum power output of the PV installation when operating at its MPP.

V_{mpp} : Voltage of the PV panel at the MPP.

R_{load} : Equivalent resistance of the load connected to the output side of the DC–DC boost converter.

D_{mpp} : Ideal duty cycle setting for the boost converter to achieve MPPT.

The MPPT block generates a duty cycle signal, which controls the switching device of the boost converter, operating at a frequency of 10 kHz. The choice of a boost converter is driven by the PV system's need for a higher output voltage, thus requiring a voltage step-up. Additionally, the selection of a boost converter is influenced by its

reputation as one of the simplest and most easily controllable types of DC–DC converters, as indicated by Eltamaly et al. (2020).

Considering the continuous conduction mode (CCM) and selecting the current through the inductor and the voltage across the capacitor as state variables, the averaged model of the boost converter, shown in Figure 1, can be defined in Eqs (7) and (8) (Manuel and İnanç, 2022; Menadi et al., 2024).

$$\frac{di_L(t)}{dt} = -(1-D)\frac{1}{L}v_o(t) + \frac{1}{L}v_{pv} \quad (7)$$

$$\frac{dv_o(t)}{dt} = (1-D)\frac{1}{C_{out}}i_L(t) - \frac{1}{R.C_{out}}v_o \quad (8)$$

where i_L denotes the current through the inductor, $v_{C_{out}}$ is the voltage across the capacitor C_{out} , and D is the control signal ($D \in [0,1]$). In the boost converter circuit, the parameters R , L , and C_{out} represent the load resistance, the input circuit inductance, and the output filter capacitance, respectively; v_{pv} is the supply voltage of the boost converter and v_o is the output voltage.

2.3. Characteristics of PV modules under static PSCs

During non-uniform irradiance conditions, such as those caused by the shadow of a tree, building, or passing clouds, the PVG system becomes partially shaded. When partial shading occurs, regardless of the cause, as illustrated in Figure 3, the power–voltage (P – V) curves display multiple peaks corresponding to MPPs. Among these peaks, only one is the global maximum power point (GMPP), while the others are local maximum power points (LMPP).

PV panels receive varying irradiance levels to simulate PSCs, which can lead to PV curves with multiple peaks. To highlight our contribution, we present a case study of static PSCs featuring four practical test scenarios for simulation:

- Scenario 1: A test under standard conditions ($1,000 \text{ W/m}^2$ and 25°C);
- Scenario 2: Static partial shading with $I_{r1} = 1,000 \text{ W/m}^2$, $I_{r2} = 400 \text{ W/m}^2$ at 25°C ;
- Scenario 3: Static partial shading with $I_{r1} = 800 \text{ W/m}^2$, $I_{r2} = 400 \text{ W/m}^2$ at 25°C ;
- Scenario 4: Static partial shading with $I_{r1} = 600 \text{ W/m}^2$, $I_{r2} = 400 \text{ W/m}^2$ at 25°C .

Simulations were conducted using MATLAB/Simulink to explore and evaluate the effectiveness of the hybrid WSO-IC algorithm for achieving optimal performance under the proposed static partial shading scenarios. The simulation results were compared with those obtained from the two traditional MPPT methods: P&O and IC.

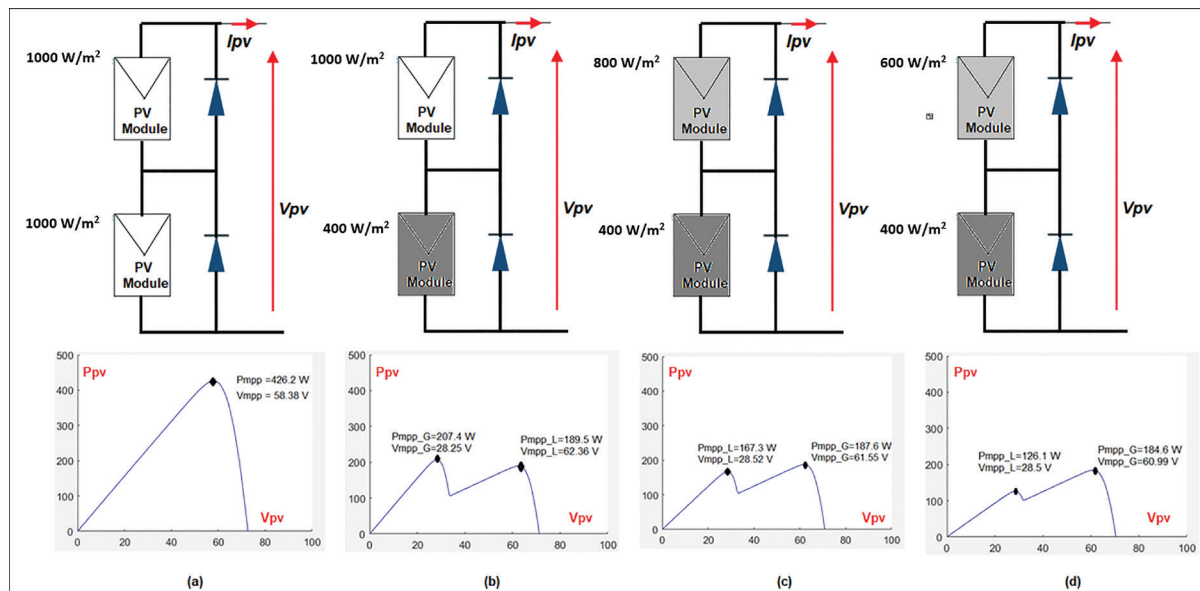

Figure 3. Configuration of PV modules under different static PSCs. (A) Scenario 1—STC. (B) Scenario 2. (C) Scenario 3. (D) Scenario 4. PSCs, partial shading conditions; PV, photovoltaic; STC, standard test conditions.

3. Hybrid WSO-IC Algorithm for MPPT

MPPT is a crucial technique used in PV systems to ensure that the system operates at its maximum efficiency. The purpose of MPPT is to find the optimal operating point on the PV curve, where the product of voltage and current (which equals power) is maximized. Given the non-linear characteristics of PV systems and the variability of environmental conditions, sophisticated algorithms are required to dynamically adjust the operating point.

In comparison, hybrid metaheuristic algorithms combine the strengths of multiple optimization techniques, often yielding more accurate and robust MPPT, especially in complex scenarios like partial shading. These hybrid methods can adapt to varying conditions more effectively but are generally more complex to implement than the IC algorithm.

3.1. IC algorithm

The IC algorithm is an MPPT technique used in PV systems to optimize energy extraction by calculating and comparing the instantaneous conductance (dI/dV) with the voltage. It continuously adjusts the operating voltage to maintain operation near the MPP with reduced oscillations, offering a balance between simplicity and efficiency. However, its accuracy can be compromised by noise and partial shading.

The IC algorithm adjusts the duty cycle D of the power converter based on the incremental changes in voltage V and current I . The condition for achieving MPP is defined as follows (Al-Dhaifallah et al., 2018):

$$\frac{dP}{dV} = 0 \text{ where } P = V \cdot I \quad (9)$$

Expanding this gives:

$$\frac{d(V \cdot I)}{dV} = I + V \cdot \frac{dI}{dV} \quad (10)$$

Algorithm 1: Incremental Conductance (IC) Algorithm for MPPT

```

1: Initialize  $D_{prev} = 0.5$ ,  $V_{pv, prev} = V_{pv}$ ,  $I_{pv, prev} = I_{pv}$ 
2: Set step size  $\Delta D$ 
3: while system is running do
4:   Measure current voltage  $V_{pv}$  and current  $I_{pv}$ 
5:   Calculate the change in voltage:  $\Delta V = V_{pv} - V_{pv, prev}$ 
6:   Calculate the change in current:  $\Delta I = I_{pv} - I_{pv, prev}$ 
7:   if  $\Delta V \neq 0$  then
8:     if  $\frac{\Delta I}{\Delta V} > -\frac{I_{pv}}{V_{pv}}$  then
9:       Decrease duty cycle:  $D = D_{prev} - \Delta D$ 
10:    else if  $\frac{\Delta I}{\Delta V} < -\frac{I_{pv}}{V_{pv}}$  then
11:      Increase duty cycle:  $D = D_{prev} + \Delta D$ 
12:    else
13:      No change in duty cycle:  $D = D_{prev}$ 
14:    end if
15:  else if  $\Delta V = 0$  then
16:    if  $\Delta I \neq 0$  then
17:      Decrease duty cycle:  $D = D_{prev} - \Delta D$ 
18:    end if
19:  end if
20:  Update previous values:  $V_{pv, prev} = V_{pv}$ ,  $I_{pv, prev} = I_{pv}$ 
21:  Set  $D_{prev} = D$ 
22: end while

```

At the MPP, the output power of the PV system is maximized, which implies that any small change in voltage (V) results in a corresponding change in current (I) that maintains the power at its maximum value. Mathematically, this condition is represented by the relationship given in Eq. (9). When we apply this condition to the derived expression from Eq. (10), this simplifies to:

$$\frac{dI}{dV} = -\frac{I}{V} \quad (11)$$

The IC algorithm adjusts the duty cycle D based on the relationship between $\frac{\Delta I}{\Delta V}$ and $\frac{I}{V}$

$$\text{If } \frac{\Delta I}{\Delta V} > -\frac{I}{V}, \text{ decrease } D$$

$$\text{If } \frac{\Delta I}{\Delta V} < -\frac{I}{V}, \text{ increase } D$$

This ensures a rapid response to changes in the PV system's operating conditions.

3.1.1. Detailed explanation of IC algorithm

The IC algorithm is a widely used MPPT technique that relies on the observation that at the MPP, the derivative of power with respect to voltage (dP/dV) is zero. The IC method calculates the instantaneous change in PV voltage (V) and current (I). Based on these changes, the algorithm determines the direction in which the duty cycle (D) should be adjusted to bring the operating point closer to the MPP. If V is non-zero, the algorithm compares the ratio I/V with the negative ratio of current to voltage ($-I/V$). If I/V is greater than $-I/V$, it means the operating point is to the left of the MPP, and the duty cycle is decreased. If it is less, the operating point is to the right, and the duty cycle is increased. This process is iterated until the operating point converges to the MPP.

3.2. WSO

WSO is a metaheuristic algorithm inspired by military strategies. It operates on a population of candidate solutions, each representing a potential duty cycle D , and iteratively improves these solutions based on their fitness (Ayyarao et al., 2022):

$$fitness = -V_{pv} \times I_{pv} \times D \quad (12)$$

Key steps in WSO include:

- (1) Initialization: Initialize a population of candidate solutions.
- (2) Fitness Evaluation: Calculate the fitness of each candidate.
- (3) Update Rules: Adjust candidate positions using:

$$Position_i^{new} = Position_i + D_v \quad (13)$$

where

$$D_v(i,:) = 2 \times RR \times (King - Position(i,:)) + W_1(i) \times rand \times (C_o - Position(i,:)) \quad (14)$$

$Position_i^{new}$ is the new position of the soldier; $Position_i$ is the previous position; C_o is the position of the commander; $King$ is the position of the king; W_1 is the weight; and RR is the threshold value.

- (4) Convergence Check: Iterate until the optimal solution is found or a maximum number of iterations is reached.

The operation of this algorithm is described in the flowchart in Figure 4.

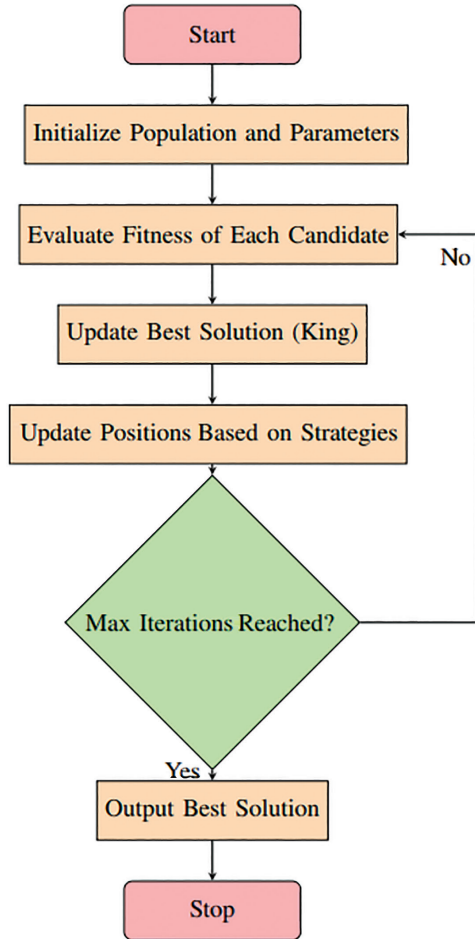

Figure 4. Flowchart of WSO algorithm. WSO, war strategy optimization.

3.2.1. Detailed explanation of WSO Algorithm

WSO is a metaheuristic algorithm inspired by military strategies. It is modelled as an optimization process wherein each soldier dynamically moves towards the optimum value. In the context of MPPT, WSO is employed to refine the search for the optimal duty cycle (D). It operates by generating a population of possible solutions (duty cycles), evaluating their fitness based on the power output, and iteratively adjusting the solutions towards the global best solution. The WSO helps avoid local optima and enhances the accuracy of the MPPT by leveraging the global search capabilities of the swarm intelligence method. Hybrid approach: The hybrid algorithm begins with the IC method to quickly narrow down the search area for the MPP. The IC algorithm provides a good initial estimate of the optimal duty cycle.

3.3. Hybrid WSO-IC approach

The hybrid WSO-IC algorithm is an advanced technique that combines the advantages of IC and WSO. It is designed to swiftly and efficiently identify the GMPP of a PV system under static PSCs, minimizing response time and enhancing overall system performance. This hybrid approach offers both fast convergence and high accuracy in tracking the MPP, making it a robust solution for PV systems.

Key steps in hybrid WSO-IC include:

- (1) **IC Phase:** Quickly adjusts D based on the local gradient to approach the MPP.
- (2) **WSO Phase:** Further refines this solution by exploring a broader search space, ensuring that the true global MPP is found.

Algorithm 2: Hybrid WSO-IC Algorithm for MPPT in Photovoltaic Systems

```

1: Initialize  $D_{prev} = 0.5$ ,  $V_{pv, prev} = V_{pv}$ ,  $I_{pv, prev} = I_{pv}$ 
2: Initialize WSO population, fitness values, and other necessary parameters
3: while not converged do
4:   IC Algorithm:
5:     Measure current voltage  $V_{pv}$  and current  $I_{pv}$ 
6:     Calculate the change in voltage:  $\Delta V = V_{pv} - V_{pv, prev}$ 
7:     Calculate the change in current:  $\Delta I = I_{pv} - I_{pv, prev}$ 
8:     if  $\Delta V \neq 0$  then
9:       if  $\frac{\Delta I}{\Delta V} > -\frac{I_{pv}}{V_{pv}}$  then
10:          $D = D_{prev} - \Delta D$ 
11:       else if  $\frac{\Delta I}{\Delta V} < -\frac{I_{pv}}{V_{pv}}$  then
12:          $D = D_{prev} + \Delta D$ 
13:       else
14:          $D = D_{prev}$ 
15:       end if
16:     else if  $(\Delta V = 0)$  and  $(\Delta I \neq 0)$  then
17:        $D = D_{prev} - \Delta D$ 
18:     end if
19:     Constrain D within [0,0.95]
20:     Update previous values:  $V_{pv, prev} = V_{pv}$ ,  $I_{pv, prev} = I_{pv}$  and  $D_{prev} = D$ 
21:   WSO Algorithm:
22:     Calculate fitness value:  $fitness = -V_{pv} \times I_{pv} \times D$ 
23:     Update WSO positions and fitness values
24:     Adjust positions based on best and global best solutions
25:     Constrain positions within [0,0.95]
26:     Check for convergence criteria
27:   end while
28: Output the optimal duty cycle D for MPPT
    
```

The operation of this algorithm is described in the flowchart given in Figure 5.

The benefits of the hybrid WSO-IC algorithm can be outlined in the following four main points:

Fast Convergence: The IC method quickly identifies a close approximation of the MPP, and the WSO further refines this by exploring the global search space, resulting in faster convergence to the MPP.

High Accuracy: The hybrid approach combines the precision of IC with the global optimization capability of WSO, ensuring accurate tracking of the true MPP.

Reduced Oscillations: The hybrid algorithm minimizes oscillations around the MPP, leading to more stable power output and higher efficiency.

Robustness: The WSO component enhances the robustness of the algorithm, making it effective even under partial shading and other non-ideal conditions (rapid fluctuations in irradiance, temperature variations, and possible mismatches between PV modules).

4. Simulation Results and Statistical Analysis

4.1. Simulation results

A series of simulation tests were carried out on the proposed MPPT control algorithm. The simulation has been realized under the MATLAB/Simulink environment using the control scheme illustrated in Figure 6.

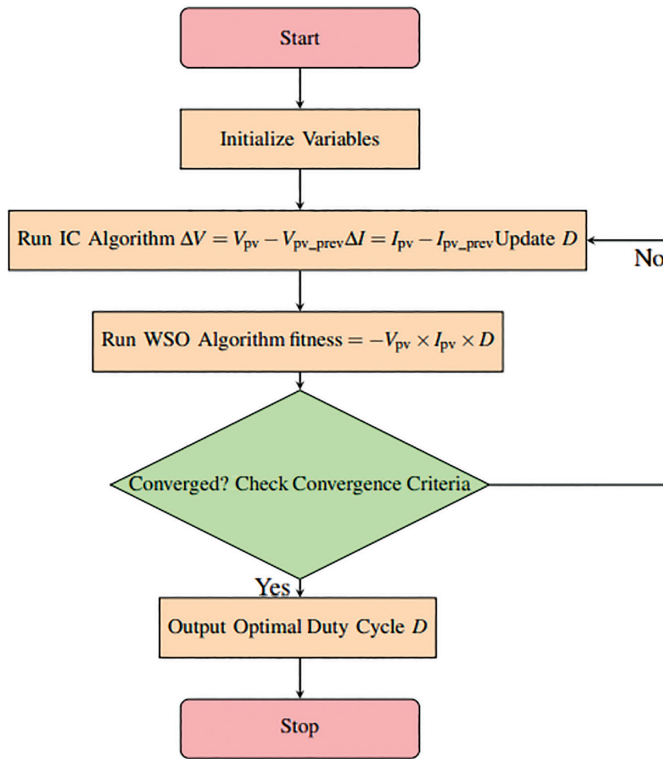

Figure 5. Flowchart of hybrid WSO-IC Algorithm. WSO-IC, war strategy optimization-incremental conductance.

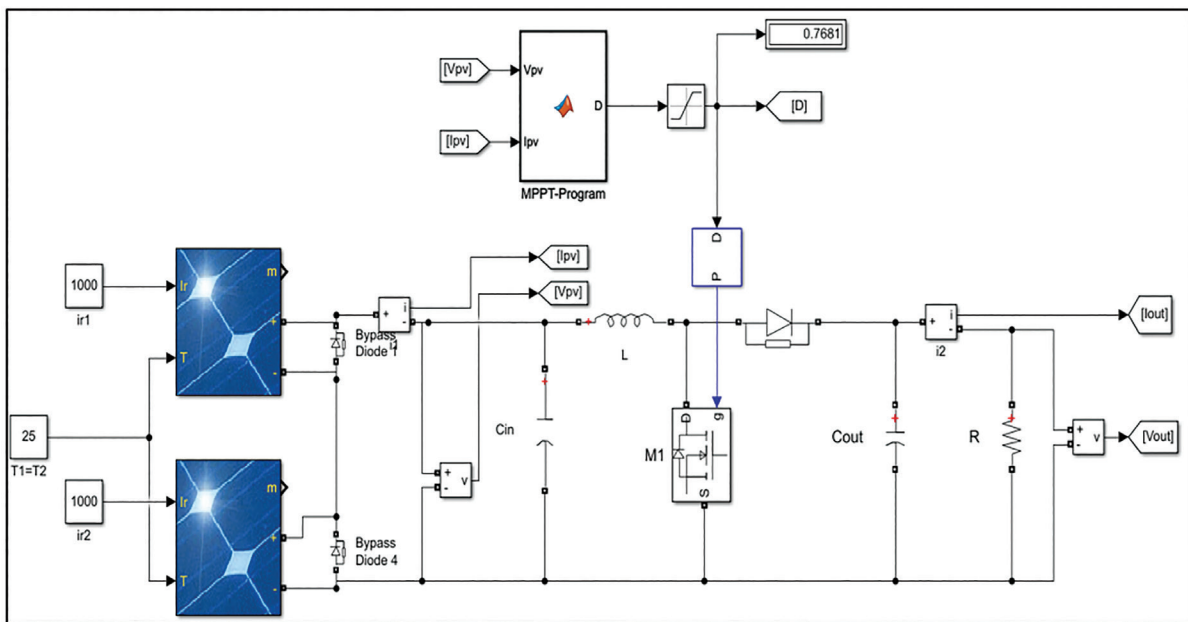

Figure 6. Diagram of the 426.3 W peak power PV system simulated in SIMULINK. PV, photovoltaic.

The DC–DC boost converter serves as an interface between the simulated PV installation and a simulated DC load, with the entire system being modelled in the simulation environment. The boost converter is used to control the operating point for current and voltage, thus facilitating the acquisition of the true MPP. In this setup, four different MPPT algorithm blocks are integrated into various sections, with each MPPT method being simulated in succession.

The primary objective of this work is to study and conduct a comparative analysis of four different algorithms for tracking the GMPP of a PV system under the influence of static partial shading. The algorithms considered are IC, P&O, WSO, and a hybrid WSO-IC algorithm. The proposed hybrid WSO-IC algorithm is utilized to further refine the search method in order to accurately track the exact location of the GMPP.

We selected the four algorithms: P&O, IC, WSO, and WSO-IC for comparison due to their complementary approaches in MPPT. P&O is widely used for its simplicity, while IC offers greater precision, especially under changing irradiance conditions. WSO was included as it is an effective global optimization method, particularly useful under PSCs. The hybrid WSO-IC combines the strengths of WSO and IC, aiming to enhance both tracking speed and accuracy. Regarding power losses in the DC–DC converter, these depend to some extent on the control algorithm. More efficient tracking algorithms can reduce oscillations around the MPP, thereby minimizing switching losses and improving overall system efficiency. Algorithms that are slow to converge or prone to oscillations can cause increased switching activity and higher losses in the converter.

The comparative performance analysis of the four algorithms involves observing three parameters to evaluate the tracking time, tracking error, and efficiency of the studied PV system.

Tracking time reflects the convergence time required by the algorithms to achieve maximum power P_{pv} .

The second parameter, **tracking error**, measures the deviation between the duty cycle determined by the algorithms and the actual global duty cycle calculated in Table 3, divided by the calculated global duty cycle. This parameter quantifies the accuracy of the algorithms in locating the MPP and is expressed as a percentage.

The third parameter assesses the **efficiency** of the PV system by calculating the ratio of the generated.

The simulation results are presented in Figures 7–10, corresponding respectively to the power P_{pv} and duty cycle for the four scenarios 1, 2, 3, and 4 of each of the four algorithms: IC, P&O, WSO, and WSO-IC. The x-axis is consistent across all four cases in each scenario, with a scale ranging from 0 s to 4 s.

In the four scenarios 1, 2, 3 and 4, the comparative performance of the hybrid WSO-IC method is demonstrated in Figures 7–10. Remarkably, this method quickly reaches the GMPP with a minimal tracking error in the duty cycle and a high efficiency in extracting the maximum power from the PV installation compared to other methods such as IC, P&O, and WSO. Notably, this objective is achieved without encountering persistent oscillations in the steady state. On the other hand, the WSO method exhibits a faster response time than the other algorithms.

4.2. Statistical analysis

The data collected during the simulation phase allowed for the calculation of the tracking error percentage in the global duty cycle for each method, as indicated in Table 4.

The results clearly show that the WSO-IC outperforms the other suggested approaches in various aspects. Notably, it excels in accurately tracking the global duty cycle (GMPP) and in its ability to operate at its maximum power. The efficiency of the WSO-IC method ranges between 0.995 and 1.000 in the four scenarios studied.

The results shown in Table 4 and Figure 11 underscore the effectiveness of the WSO-IC method in optimizing the MPPT process for PV systems. The superior convergence speed and efficiency percentage of this method

Table 3. Optimal duty cycle calculated for each scenario

Scenario	P_{mpp} (W)	D_{opt}
Scenario 1	$P_{mpp} = 426.3$	$D_{opt_G} = 0.71721425$
Scenario 2	$P_{mpp_G} = 207.4$ $P_{mpp_L} = 189.5$	$D_{opt_G} = 0.80383836$ $D_{opt_L} = 0.54699656$
Scenario 3	$P_{mpp_G} = 187.6$ $P_{mpp_L} = 167.3$	$D_{opt_G} = 0.55062217$ $D_{opt_L} = 0.77950357$
Scenario 4	$P_{mpp_G} = 184.6$ $P_{mpp_L} = 126.1$	$D_{opt_G} = 0.55110705$ $D_{opt_L} = 0.74620251$

P_{mpp_G} : Power output in global peak point.

P_{mpp_L} : Power output in local peak point.

D_{opt_G} : Optimal duty cycle corresponding to global peak point using Eq. (6).

D_{opt_L} : Optimal duty cycle corresponding to local peak point using Eq. (6).

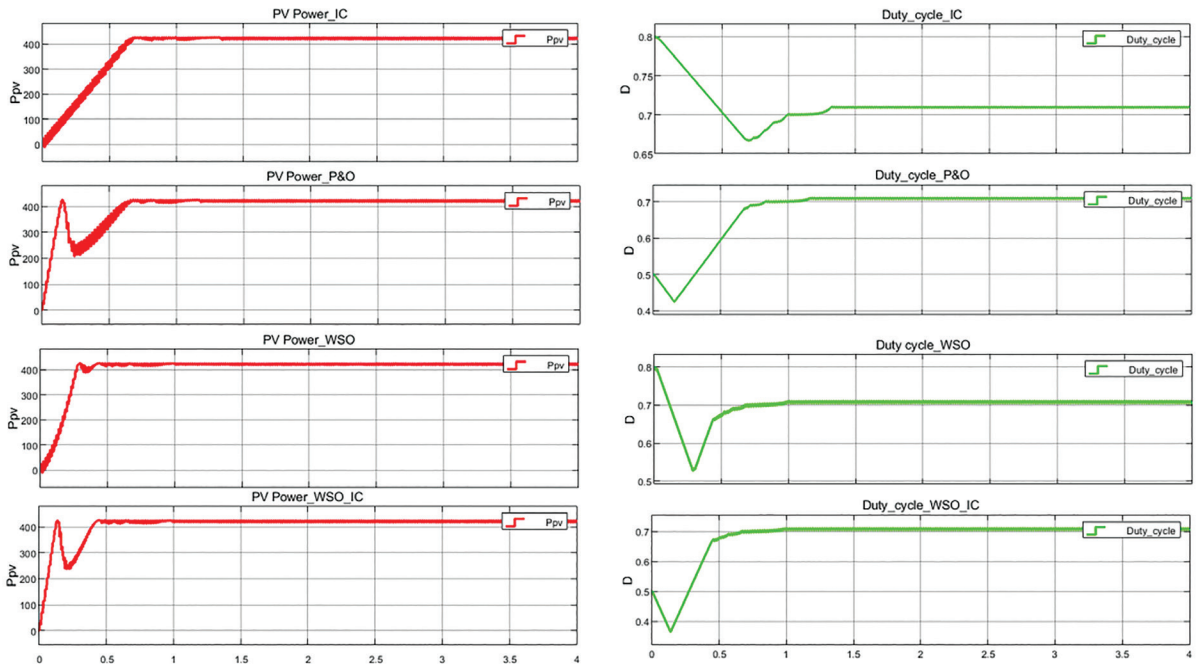

Figure 7. Power P_{pv} and duty cycle under standard conditions (Scenario 1-STC). STC, standard test conditions.

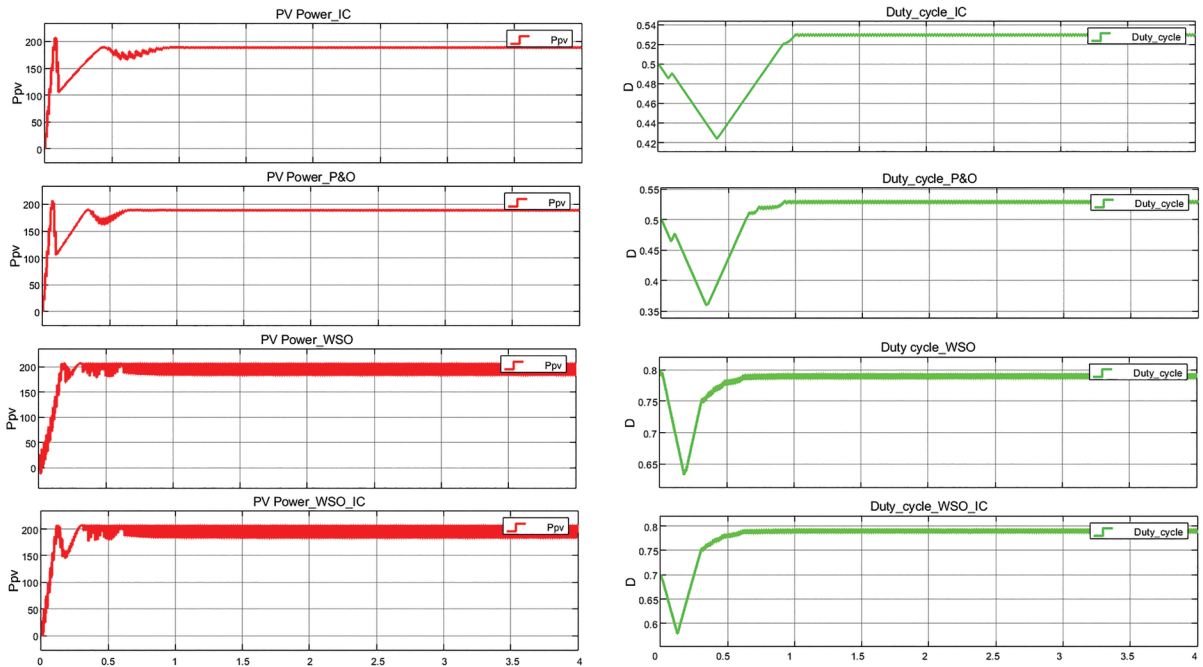

Figure 8. Power P_{pv} and duty cycle under PSCs (Scenario 2). PSCs, partial shading conditions.

highlight its potential as an essential choice for optimizing energy production and overcoming shading challenges in PV applications.

The hybrid approach, which integrates IC and WSO, is designed to capitalize on the strengths of both methods. The IC algorithm facilitates a quicker initial convergence to a region near the MPP, while WSO fine-tunes the search to ensure the attainment of the global MPP, particularly in partial shading scenarios. Although WSO performs well on its own, incorporating IC aims to decrease the overall duty cycle tracking error and enhance efficiency—key

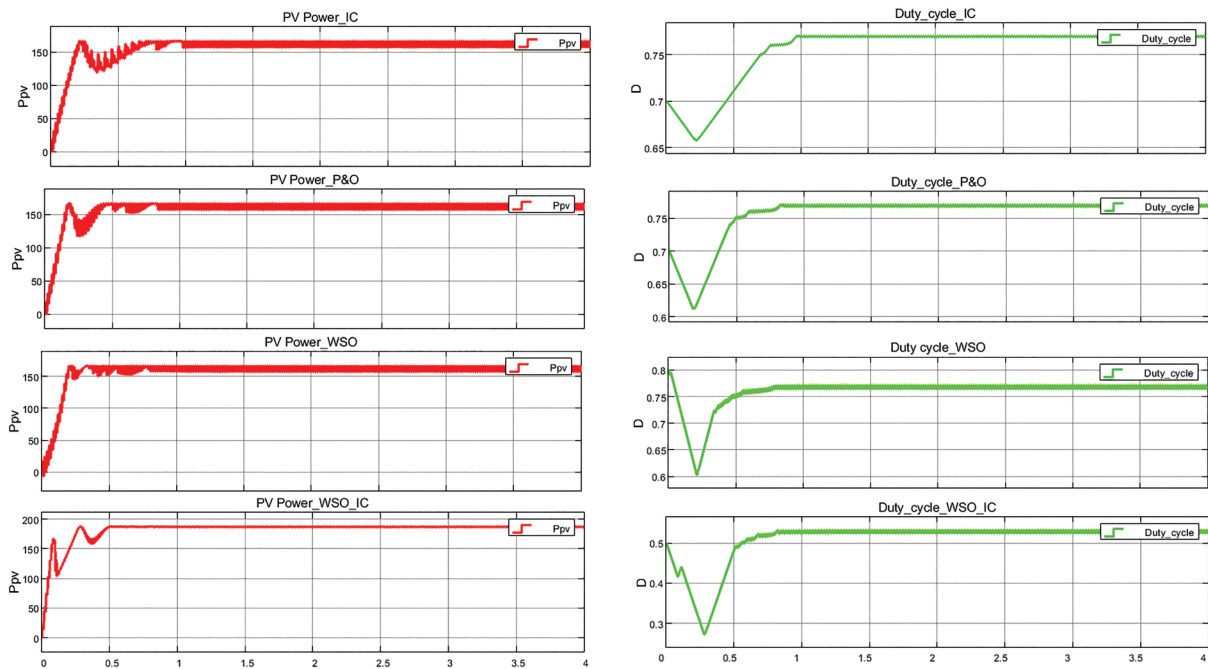

Figure 9. Power Ppv and duty cycle under PSCs (Scenario 3). PSCs, partial shading conditions.

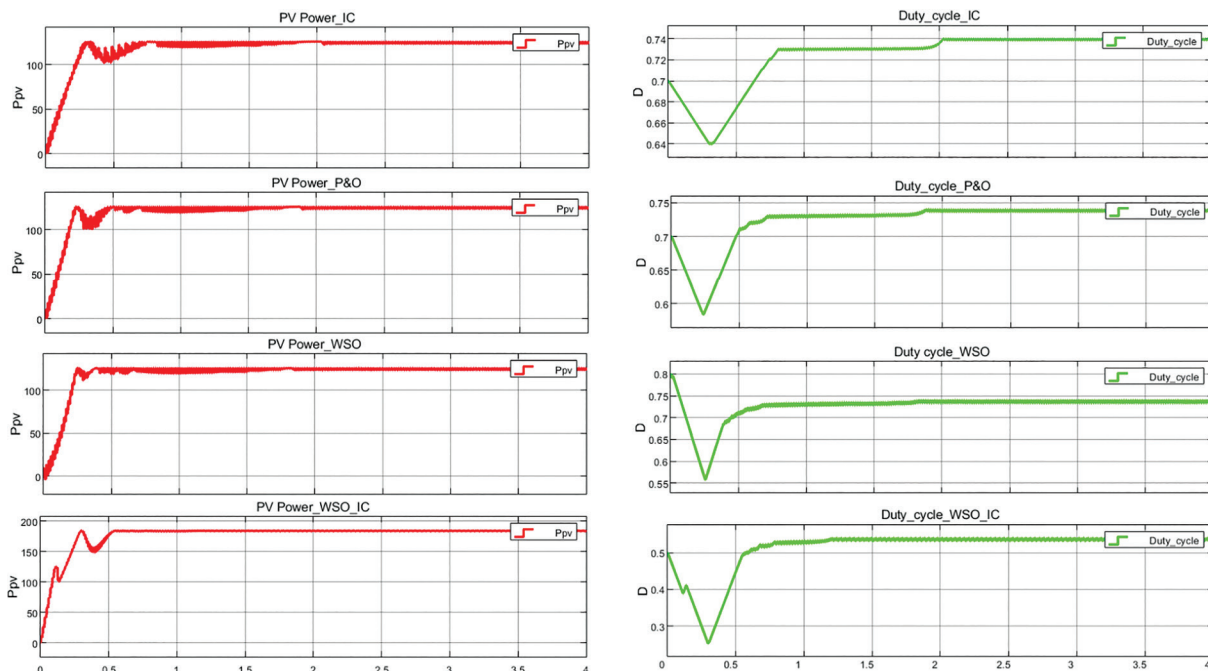

Figure 10. Power Ppv and duty cycle under PSCs (Scenario 4). PSCs, partial shading conditions.

factors for the system's performance. To comprehensively evaluate the performance of the proposed WSO-IC MPPT controller compared to other methods, a set of key performance indicators (KPIs) was used. These KPIs, detailed in Table 5, include:

The results presented in Table 5 clearly indicate that the WSO-IC algorithm outperforms other methods in several key areas. Based on the simulation obtained data, the percentage efficiency for each method was calculated. It is evident that the WSO-IC method achieves significantly higher efficiency compared to the techniques discussed by

