

AN OVERVIEW OF DESIGN, CONTROL, POWER MANAGEMENT, SYSTEM STABILITY AND RELIABILITY IN ELECTRIC SHIPS

KAI NI, YIHUA HU, XINHUA LI

University of Liverpool, L69 3GJ Liverpool, United Kingdom,
e-mail addresses: k.ni@student.liverpool.ac.uk, Y.Hu35@liverpool.ac.uk,
xinhua.li@liverpool.ac.uk

Abstract: With the fast development of power electronics techniques, electrification of shipboard power systems (SPS) is an unstoppable trend, and the concepts of electric ships (ESs) and all-electric ships (AESs) emerge. In order to meet the constantly increasing electricity demand in SPS, the medium voltage direct current (MVDC) SPS becomes a promising shipboard electrical network architecture. This paper aims to present a comprehensive review of the design, control, power management, system stability and reliability in ESs. The most recent technologies and academic achievements in these fields are discussed. In the near future, it is possible that the electric propulsion technology will be widely applied to various types of ships.

Keywords: *electric ship, control algorithms, power electronics techniques, power drive system, stability*

1. INTRODUCTION

Recently, electric propulsion has been developed for various types of vessels, thanks to the rapid development of semiconductor switching devices, which can be applied in high power drives [1]. Owing to the requirement of saving fuel consumption, electric propulsion in commercial ship applications is widely used, which substitutes the original mechanical counterparts. In the future electric ship (ES) applications, multiple energy sources, independent operation of individual power producers, and energy storage for different types of applications will be allowed for further increasing the system efficiency [1].

The history of ES dates back to over a century ago [2], where a limited number of such applications was presented. Massive production of ESs was not realized until the 1980s, since at that time the maturity of semiconductor technology was high enough for variable speed control of electric motors. The electric propulsion system utilizes a number of small units for power generation instead of a big prime mover, in which case the generator engines are always loaded close to their optimal operating points [1]. By applying electric propulsion on ships, the placement of equipment onboard is flexible,

which eliminates the negative impacts caused by using long shaft-lines to the propellers. In [3], the past, present, and future challenges of the marine vessel's electric power system were discussed. There are a number of variants for electric propulsion solutions which are dependent on the type of vessel, operational profiles, and the current available technologies for construction [1]. Three different application areas of electric propulsion systems for ships were introduced in [1], which are 1) ocean going, where the criteria of propulsion design is a certain vessel speed with flexibility in operating at different speeds, 2) station keeping, whose main target is performing an operation safely by keeping position, 3) icebreaking, where a propulsion design tradeoff has to be considered among a high bollard pull demand, propeller over-torque, and open water efficiency [1]. It was also indicated that the future trends and technologies for ES involve DC grid, energy storage, hybrid propulsion and dynamic position (DP) closed bus. Furthermore, future electrical energy sources can be accommodated for the ESs, since the relevant necessary infrastructures are available onboard. According to [4], the following advantages have been proven by applying electric propulsion in ship applications: 1) better dynamics can be derived, 2) electrical motors are likely to be more flexibly accommodated without using extremely long shaft lines, and the rudder may be omitted by possible installation of outer rotating pods, 3) the fuel consumption is reduced, 4) higher comfort is derived since vibrations are mitigated, 5) higher level of automation of the engine rooms.

Furthermore, the concept of all-electric ships (AESs) was raised as the use of electric power equipment is able to replace the traditional power sources in mechanical or hydraulic forms, and several merits can be derived by adopting AES, which are listed as shown below [5].

1) The allocation of equipment is flexible, 2) more degrees of freedom are introduced in the layout design of the power system, 3) the shafts and rudder are omitted, 4) the system lifetime is prolonged, 5) propeller dynamics is enhanced, 6) modularity of generators is presented, 7) the efficiency of managing the heating, ventilation, and air conditioning systems is improved, 8) attenuation of noise and vibration is derived, 9) human resource reduction due to advanced automation, 10) increased survivability and maintainability.

The AES concept has become a standard in the field of large cruise ships that covers the construction made by the major shipyards all over the world [5]. The application of electric propulsion is now observed in various types of ships, including ferries, gas carriers, vessels, icebreakers, and offshore oil and gas platforms [5].

This paper gives a comprehensive overview on the design, control, power management, system stability and reliability of ESs in the following sections. The most recent technologies and research achievements in these fields are presented. In the final section, a conclusion is drawn.

2. DESIGN

In order to make ESs work properly, reasonable design is the first step, and it is of paramount significance to take as much as information into consideration earlier in the design stage. In [6], an overview was carried out for the design stages of US Navy ships, where the design procedures can be classified as concept design, engineering design, and production design. In the concept design procedure, the expressed need is to be met by considering a defined gap in operational capability, and the future evaluation of ship design alternatives are produced with the consideration of the mission requirements, concept of operations (CONOPS), and operational environment. In addition, the possible ship concepts are derived in the analysis of alternatives (AoA) phase to meet the high-level mission requirements and capabilities. Preliminary design and contract design are included in the engineering design process, where the establishment of basic architectures is done for the ship and systems, and more details are added to the preliminary design in the contract design process. Afterwards, the engineering data is applied in the process of verifying if all the specifications are met for the ship in the product design process, which aims to complete the detailed design and construction. The design stages can be depicted in Fig. 1.

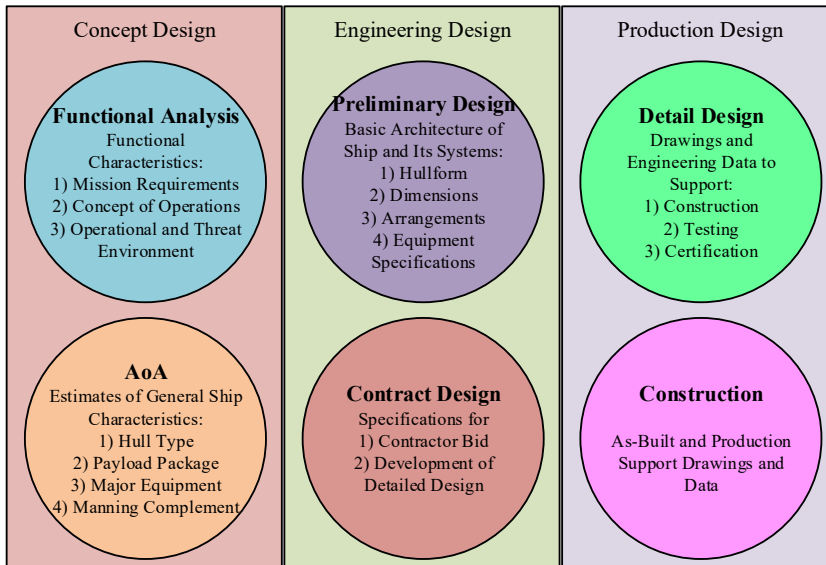

Fig. 1. The design stages for US Navy ESs [6]

As is presented in [6], the inside-out ship design concept was raised in [7]. If the design is made following the process of designing the external structure first, then an extremely dense ship design may be caused due to the external constraints, which results

in difficult production and maintenance, and it increases the life-cycle cost of the ship class [7]. Following this concept, several projects were taken at MIT Sea Grant, including the projects regarding a functional arrangement by selecting modular blocks for payload and machinery [8], creating additional permutations based on prearranged machinery spaces [9], and hydrodynamically-optimized hulls produced within user-specified constraints [10]. In addition, an objective function was maximized to improve the packing density, and the components and compartments were located in the places as close to the ideal ones as possible in [11], which was completed by a packing approach. Furthermore, the evolutionary process of configurations for merchant ships, cruise ships and military ships is displayed in Table 1 over the past few decades, at present, and in the possible future [12].

Table 1. Ship configurations [12]

Period of use	Merchant ships	Cruise ships	Military ships
Half of the last century	Stream plants – mechanical propulsion		
Present	2 strokes diesel engine mechanical propulsion	electric generators electric propulsion	gas turbines mechanical propulsion
Possible future	electric generators and new generation power distribution – electric propulsion		

AES has been developed for a long time, and with the emergence of power electronic converters and the rapid progress made in this field, the power systems utilized in AES is transferring from electrical propulsion based ones to integrated electrical and electronic ones. The importance of design methods of integrated electrical and electronic power systems (IEEPSs) for AES was demonstrated in [4] through an overview of the latest results derived in technological research. A large number of design methodologies have been proposed in papers [6, 13–18], where the simplest and most relevant one is called the design spiral [6]. By utilizing this method, the most general details are derived first, and then more detailed design levels are developed, in which case the current iteration can be revised by using the information obtained from previous design cycles.

3. CONTROL

In the advanced ESs and AESs, the control of shipboard electrical power systems highly relies on the control of power electronic devices, which are capable of coordinating the power flows between AC and DC subsystems. In addition, with the evolution of integrated power systems (IPSs) in ESs, the requirement of saving on-board space and flexible power delivery becomes stricter, which can be met by developing more advanced power electronics technologies and control strategies.

3.1. POWER ELECTRONICS TECHNIQUES

As the demand of electricity in an ES is constantly increasing, higher power rating is desired. Apart from that, increasing the power density and system reliability is also of paramount importance. Therefore, instead of basic voltage source converters (VSCs), a number of advanced topologies are investigated for applications in power conversion modules in ESs. In general, the possible advanced VSC topologies to be used in ship-board IPSs include multilevel converters [19–21], interleaved converters [22], multi-phase converters [23, 24], soft-switched converters [25], and power electronics building blocks (PEBBs) [26, 27].

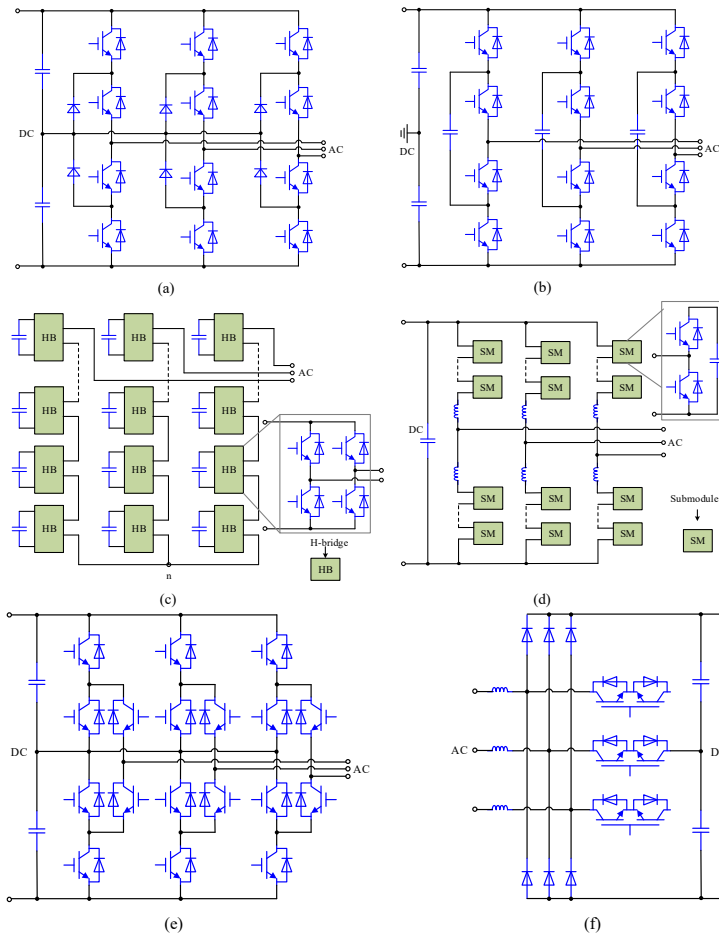

Fig. 2. Multilevel converters: a) three-level neutral-point-clamped (NPC) inverter, b) three-level flying capacitor (FC) converter, c) cascaded H-bridge (CHB) converter, d) modular multilevel converter (MMC), e) three-level active NPC (ANPC), and f) a Vienna-type rectifier [28]

In [28], the authors summarized typical topologies for multilevel converters, which are already widely used in a variety of power systems. The structures of the main categories of multilevel converters are shown in Fig. 2, with the comparison among them displayed in Table 2.

Table 2. Summary on multilevel converter comparison [28]

Topology	NPC	FC	CHB	MMC	Vienna-type	ANPC
Device utilization rate (two-level VSC as the basis)	1.25	1	1	1–2	1	1.5
Modularity	no	no	yes	yes	no	no
Capacitors	low	medium	high	high	low	low
Inductors	low	low	low	high	low	low
Transformers	low	low	high	low	low	low

Assume two-level VSC is 1.

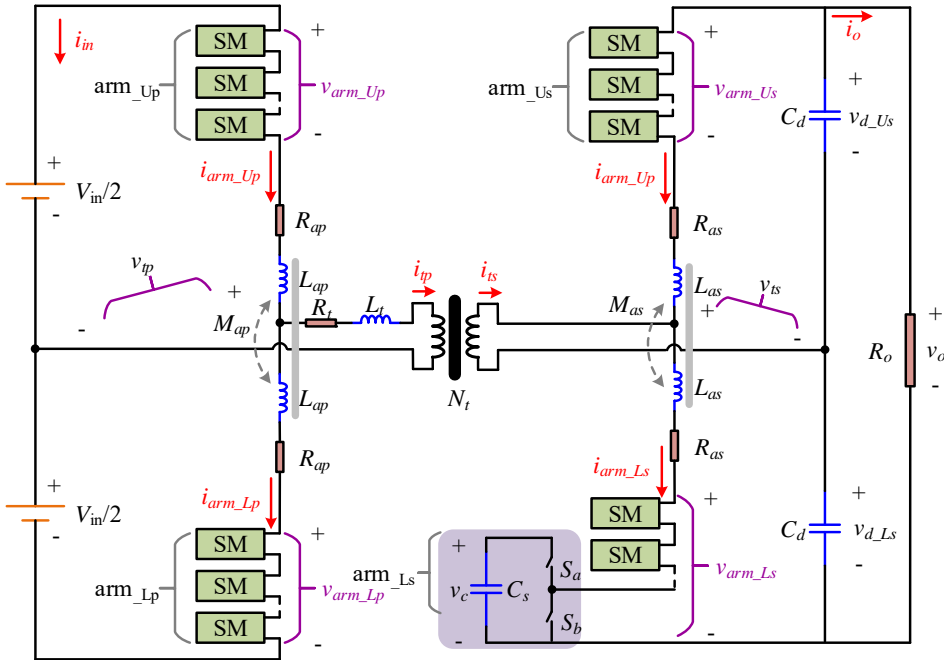

Fig. 3. Proposed DC-DC MMC system for ES MVDC application [33]

Owing to the superiority of modular multilevel converter (MMC) over other multilevel converter topologies in terms of high modularity, high scalability, high efficiency, excellent harmonic performance, and elimination of dc-link capacitors, it has been widely investigated [29, 30]. An approach to developing a scalable metamodel for compatible MMCs was presented in [31], and the size/weight/efficiency was produced to

achieve the required voltage and power ratings. In [32], a hybrid energy storage system (ESS) based on isolated modular multilevel DC/DC converter was proposed with active filter function for shipboard medium-voltage direct current (MVDC) system applications to improve the bus power quality and achieve superior fault response. In [33], the modelling and control of an isolated DC-DC MMC with a medium-frequency AC-link transformer was investigated for ES MVDC power system. The proposed DC-DC MMC system in [33] is displayed in Fig. 3.

In an isolated DC-DC MMC, the bridge arms are formed by using several submodules (SMs). Therefore, different voltage levels are derived in this topology, and the voltage balancing is easy as only float capacitors are involved in the SMs. In addition, the fundamental frequency modulation technique in [34] was employed for minimizing the switching losses of each SM by reducing the switching times, which allows further alleviation of the leakage current. Moreover, the useful model information for control purposes was maintained, which enables the steady state and small-signal analysis.

As the power demands for ESs are continuously increasing, the material theoretical limits of the commonly used Si power semiconductor devices are to be reached, in terms of conduction and switching performance characteristics [28]. Under such a circumstance, the wide-bandgap (WBG) semiconductor devices [35], including silicon-carbide (SiC) [36] and gallium-nitride (GaN) [37] based ones, are emerging to replace the traditional Si-based ones.

3.2. CONTROL SCHEMES

The control strategies for various applications in ESs have been investigated, and some of them will be reviewed in this section to illustrate the development in this field. In AES applications, the power quality may be seriously deteriorated by pulse loads, which require a very high amount of energy during an extremely short period of time [38]. Therefore, the approaches to improving the power quality in a ship power system is required after the occurrence of pulse loads. In [39], a distribution static compensator (DSTATCOM) based on artificial immune system (AIS) was applied for compensating the insufficient power supply in AES power system in address to pulse loads, and an adaptive control strategy was proposed. In the proposed control strategy, the particle swarm optimization (PSO) algorithm was first applied for deriving the optimal parameters of the controller. In this case, online adaptive system identification and control are possible to be achieved, which do not rely on any prior knowledge. By using the proposed PSO algorithm based control strategy for DSTATCOM in AIS based AES, good voltage regulation at the point of common coupling can be guaranteed since proper tuning of DSTATCOM was accomplished. Meanwhile, when the system returns to the normal stage after the pulse loads, the original optimal controller parameters can still be reserved. In [40], a fuzzy-based PSO (FPSO) algorithm was proposed to minimize the

operation cost, limit the greenhouse gas (GHG) emissions, and satisfy the technical and operational constraints of a ship simultaneously.

In order to mitigate the influence on the voltages at neighbouring buses in a diesel-electric ship due to the utilization of an active power filter (APF), model predictive control (MPC) was proposed in [41] to minimize the harmonic distortions of the whole system with a given APF rating. Focusing on isolating the negative impacts produced by pulsed power loads (PPLs) in a shipboard power system, cooperative controls of the generation control and ESS charging control were presented in [42]. The PI-based and feedback linearization based control algorithms were respectively performed and analysed in that paper. In [43], by taking multiple impact factors into consideration, the detailed modelling and analysis of the active foldback control were illustrated. The thyristor rectifier system in a DC powered electric ship is able to deal with the surge current without a dc inductor, if a proper active foldback control is available.

An online design and laboratory hardware implementation of an optimal excitation controller based on an AIS algorithm was proposed for improving the performance of future ESs used for navy applications in [44]. The demand for the capacity of energy storage devices can be reduced by applying an improved excitation control to minimize the effects of pulsed loads, which is based on a clonal selection algorithm (CSA). In [44], the possibility of energy storage reduction was explored by considering the situation that high-power pulsed loads are directly powered from the DC side.

Additionally, the PSO based algorithm implemented in [45] was compared with the proposed CSA method, focusing on the performance and computational complexity for real-time tuning. The general comparison of these two algorithms for excitation controller design is illustrated in Table 3.

Table 3. General comparison of CSA and PSO algorithms for excitation controller design [44]

Requirements	PSO	CSA
Computational functional complexity	small, mainly “add, subtract, multiply” operation; 3.3 million clock cycles per particle in one iteration with 150 MHz frequency	large, contains “sorting, round, exponential, and division operation” 9.6 million clock cycles per antibody in one iteration with 150 MHz frequency
Computational memory requirements	small, mainly “particles position and velocity”	medium, “antibody, affinity, new group of antibody and affinity”
Hardware requirements	low, many microcontrollers such as PIC, DSP are available to be implemented on, Shallow memory requirements	high, high processing speed is needed, memory requirements high.
Convergence	good	better
Algorithm code execution time	small	large, nearly 3 times larger than PSO

In addition, an AIS-based control of generator excitation systems for the U.S. Navy’s ES was proposed in [46], which aims at solving the high-energy load related problems

that deteriorate the power quality. The existing methods for maintaining power quality in an IPS for ES are applying immediate energy storage device and optimizing the excitation systems. For the former one, the system's cost is increased and larger ship space is required, while for the latter one, different kinds of deficiencies are presented. The computational intelligence (CI) methods are widely used at present, including fuzzy set theory [47], PSO theory [48], online trained neurocontrollers [49], and genetic algorithm (GA) [50–53]. However, the optimal performance cannot be ensured when it is out of the range of operation conditions considered in the design. Moreover, adaptive excitation controllers should be used in the cases when the performance degrades, while it is challenging to design multiple excitation controllers for U.S. Navy applications in order to obtain the optimal performance when the operating conditions vary. The proposed AIS-based control of excitation controllers for ES applications in [46] were employed to minimize the voltage deviation and power losses when pulsed loads are directly energized by the shipboard's power system. Optimal performance was provided when known disturbances were injected, and better performance can be obtained by adapting the parameters for unknown disturbances, which demonstrated its innate and adaptive immunities.

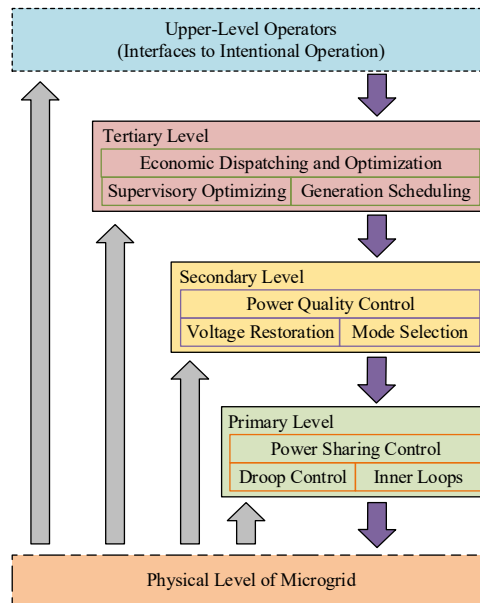

Fig. 4. Different levels in hierarchical control [54]

The smart grid and dc microgrid technologies have been introduced into shipboard electrical networks in [54], indicating the developing trend of the next-generation shipboard DC power system. In such a complicated system, with the purpose of obtaining different control functions, the hierarchical control scheme was proposed, which can be

divided into the following typically defined control levels [54]: 1) primary control, aiming at locally controlling the output voltage and current of the power electronic interfaces, 2) secondary control, which handles the restoration of voltage or frequency, manages the power quality and deals with power exchange with the external grids in the same layer, 3) tertiary control, which is responsible for managing the power exchange between the microgrid and its upper-layer grid. The typical scheme of hierarchy control is displayed in Fig. 4.

4. POWER MANAGEMENT

Since the AC power grid is commonly used in current ES applications, medium-voltage AC (MVAC) was applied in [55], and the power conversion is completed by using solid-state transformers (SSTs) [56, 57]. However, the challenge of applying such MVAC power systems induces several problems. For example, the size of SST is large, and synchronous generators are required, and it is necessary to implement reactive compensation. As a promising alternative, the MVDC [58–62] power systems make the generators paralleled even if the system is integrated with asynchronous machines. Additionally, since there is no frequency limitation for the generators, it is possible to eliminate the gearbox between the prime motor and generator, which reduces the overall cost and increases the system reliability. Apart from that, the system losses are reduced due to the fact that no reactive power transmission and skin effect need to be considered [33]. To clearly illustrate the difference between these two categories of shipboard power systems (SPS), their structures are shown in Figs. 5a, b, respectively.

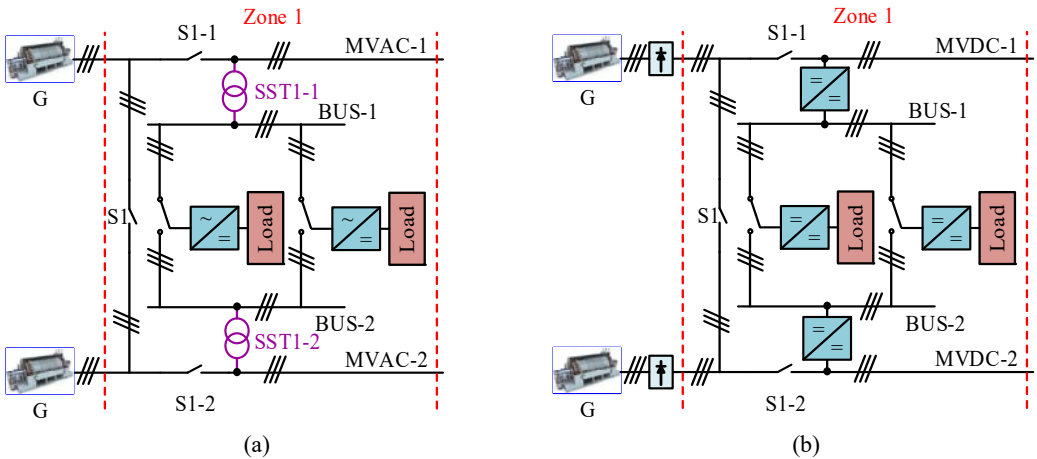

Fig. 5. Power system for ES: a) MVAC power system with SSTs, b) MVDC power system with DC-DC converters [33]

The MVDC SPS architecture has been extensively investigated owing to the advantages mentioned above, and the reason why DC distribution contributes to the most efficient ship was explained in [63] with a comprehensive review of the challenges, state of the art and future prospects. For a determined MVDC system, the settings of DC voltage reference and the optimal power reference have to be defined in advance for the VSCs operating in the voltage regulator mode and power dispatcher mode, respectively [50]. The equivalent circuit for this configuration is shown in Fig. 6.

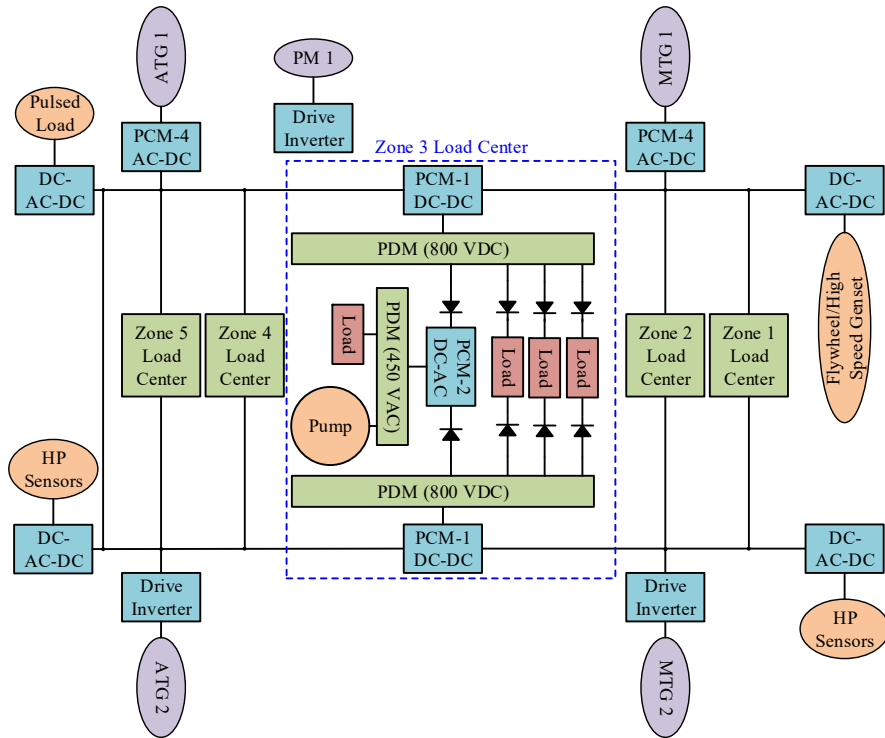

Fig. 6. MVDC architecture of SPS [64]

There are four generators in this MVDC architecture, including two main generators (MTG1 & 2) and two auxiliary ones (ATG1 & 2). The power delivery in this SPS is generally realized by a medium voltage DC ring bus, which is fed by the generators through transformers and AC-DC converters, and it operates at 5 kV. In this SPS, the DC power is distributed among five zones including the loads, VSCs, power conversion modules (PCMs), and power distribution modules. The 5000 V DC voltage is stepped down to an 800 V one by PCM1, while PCM2 is used to perform DC-AC conversion to supply AC zonal loads such as the propulsion motor (PM). In addition, the PCM4s are usually connected to the generators, playing the roles of AC-DC converters. Moreover, energy storage devices, a pulsed load device, a pump, and high power sensors are in-

volved in this system [65]. Furthermore, a methodology for power flow studies in ship MVDC distribution systems for system planning was proposed in [66] to determine the proper shipboard generator-power converter scheme.

An integrated power system (IPS) is usually favoured in an AES, which eliminates the use of separated internal combustion engines (ICEs) [5]. In this case, electric power can be distributed to wherever it is needed, and the size of the ship can be optimized, along with the combustion onboard. The typical IPS layout of an AES is displayed in Fig. 7.

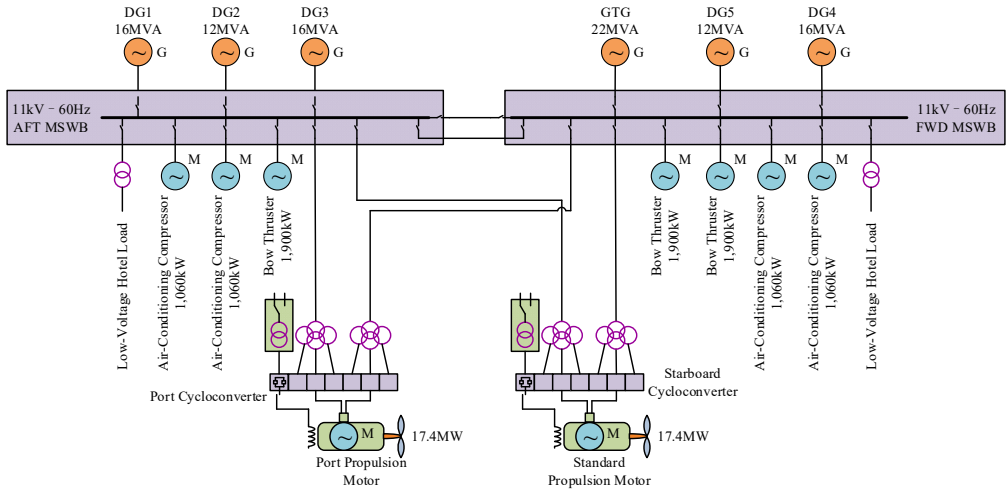

Fig. 7. The typical IPS layout of an AES [5]

The electric power in an AES is supplied from more than one separate power stations, and at least two generator sets are used in each of them. A prime mover, a synchronous machine, and all the corresponding subsystems needed are contained in each set. From Fig. 7, it can be seen that a conjunction breaker is applied to make it possible for the power stations to operate separately when feeding the separate busbars. The ship's loads can be fed by several means, where the busbars and transformers are commonly employed for this purpose [5].

Since IPS is a commonly used system configuration for AES to meet the increasing ship-board power demand and the requirement of sustainable development, power management of IPSs in AESs with time scale separation for real-time large scale optimization was investigated in [67]. Gas turbine/generator and fuel cell were considered as the power sources and the optimal power split between them was to be achieved with respect to energy efficiency, power tracking, and component safety. The optimization methodology was based on the sensitivity function method (SFM) [68], where the main idea was to make the control solutions at each level available in real-time by leveraging the multi time scale property of the IPS and solving a two-level simplified optimization

problem. By applying SFM, the computational effort can be reduced and simplification of the IPS model can be achieved to some extent.

The multi-agent system technologies are promising candidates to address challenging issues in power systems. In [69], a novel multi-agent system-based (MAS-based) real-time load management technique was proposed to determine the switch status of loads in DC zones and satisfy the operating constraints of the system in real-time simultaneously. A reduced-order agent model and artificial potential function of the MAS were utilized as the basis for the developing the cooperative control protocol. The developed MAS framework was illustrated by using a two-zone notional AES power system. By using the proposed real-time load management technique based on MAS framework, the amount of load shedding is dynamically minimized when the available power source capacity constraint is violated. In addition, the disconnected loads can be dynamically restored if more power is available in the system, in which case the restoration time for loads is greatly decreased. Furthermore, the nominal value of the system frequency can always be obtained. The diagram of a general multi-agent distributed control system for real-time load management in AES power systems is shown in Fig. 8.

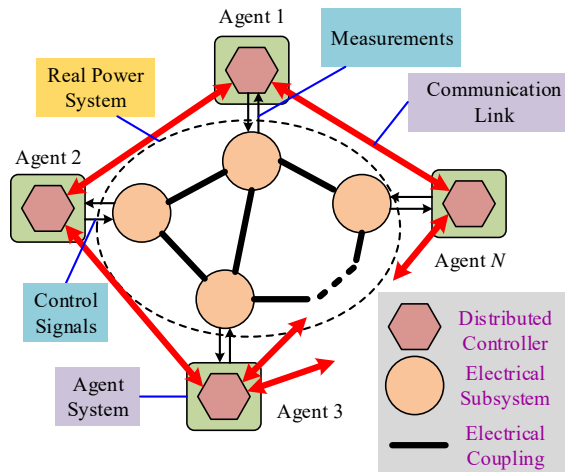

Fig. 8. Diagram of a general multi-agent distributed control system for real-time load management in AES power systems [69]

On the other hand, a MAS-based system cooperative controller for real-time electric load management in MVAC AES power systems was proposed in [70] to balance load and generation. Meanwhile, the system's operational constraints were satisfied and the load priorities were taken into consideration. The decentralized MAS cooperative control method was first applied for solving the secondary control problem in ship power systems in [70]. In the proposed method, there is no need to change the existing system design when integrating new components into the MAS. Additionally, the mission-crit-

ical loads such as high energy weapon loads in Navy applications, are always served during emergency conditions. On top of that, the pulse load and propulsion load were successfully coordinated so that the impact of the pulse load on the system power quality was reduced. Moreover, the system can still be controlled by the decentralized control framework as that in normal cases when the communication system failure is encountered [70].

Aiming at reducing the fuel consumption and GHG emissions for AES power systems, the optimal operation of a ship electric power system with full electric propulsion and energy storage system was analysed to minimize the cost, limit GHG emissions, and obey the corresponding technical and operational constraints at the same time in [71]. In the proposed power management strategy, the optimization goals were obtained by the means of energy storage and propulsion power adjustment. Three stages were used in the proposed method owing to the complexity of the examined problem. Different from the method proposed in [71], no energy storage system and investment capital are required for ship power system operation optimization in the optimal demand-side power management method for AES raised in [72]. In this approach, dynamic programming was employed as a solution and the ship load forecasting was assumed to be available. In addition, the proposed method was applied to a cruise ferry with integrated full electric propulsion, with the simulations under realistic operation situations presented. In [73], the dynamic positioning (DP) system was applied as dynamic energy storage on diesel-electric ships, and new simple formulas were derived to relate the dynamic energy storage capacity to the maximum allowed ship position deviation. The operational availability and safety were maintained by applying the integrated approach, meanwhile the power consumption was minimized.

A novel integrated security-constrained model-based power management approach was proposed in [51], which was used in isolated microgrids in AESs during the normal/alert operating state. The novelty of the study is that the objectives for various control methods were combined together by formulating the integrated security-constrained power management (ISCPM) method as a multi-objective optimization problem. In addition, dynamic security of the system was guaranteed in the proposed ISCPM formulation when planned and unpredicted scenarios are encountered. The proposed method was applied in a notional isolated microgrid power system model for an AES, whose structure is displayed in Fig. 9.

The ESS [74] in an ES plays an important role for coordinating the power flow in IPS, and a methodology for power generation controls of fuel cells (FCs)/energy storage hybrid SPS was presented in [75]. In order to support the MVDC SPS, a fuzzy logic (FL) based energy storage management (ESM) system was proposed in [76] and compared with a PI based one. Instantaneous reference powers for charging and discharging of these energy storage devices were provided, with two power sharing strategies design in this study. Compared with the PI controller based ESM system, no extra deep discharging and overcharging protection controller is required for the proposed FL based one, which mitigates the damage to the MVDC system of AES. Besides, an energy

management system (EMS) using PSO was proposed in [77] aiming at reducing fuel consumption in optimization of the vessel’s machinery systems during its voyage. Additionally, a novel FC power management scheme without employing DC-DC interfacing converters was proposed in [52], which maintains the performance of FC and thus the optimal power sharing between the FC and the lithium-ion battery in AES application was achieved. Furthermore, an IPS based on FC, battery, photovoltaic panels (PVs), and two diesel generators was proposed and modelled for AES in [78]. The appropriate control strategies of the nonlinear models for different modules in the hybrid power system of AESs and the corresponding power management approaches were focused on. With the application of the proposed decentralized MPC method in different parts of the onboard power system, the reference values were precisely followed, and the DC-link voltage variation was maintained within an acceptable range by employing the hierarchical-droop control strategy.

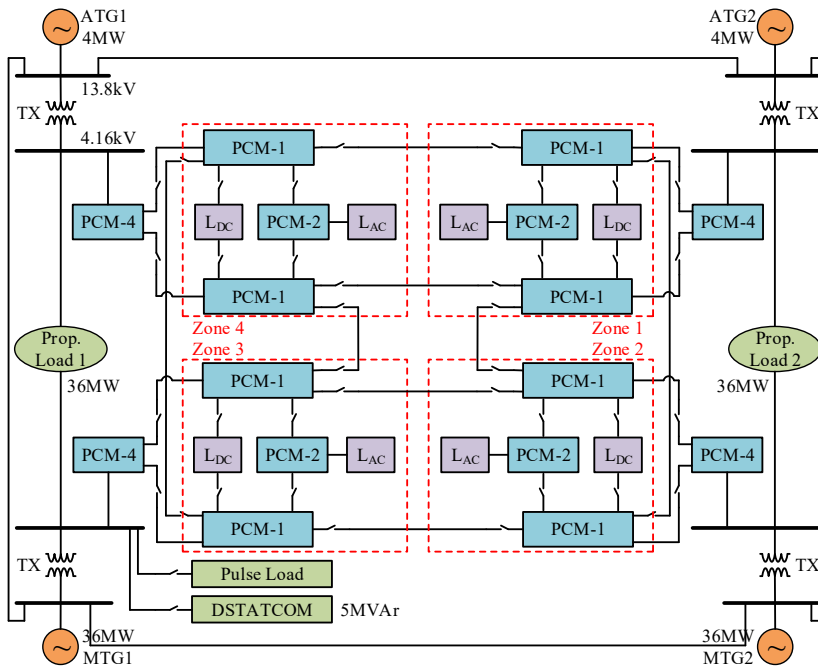

Fig. 9. Single line diagram of the notional AES model [51]

5. SYSTEM STABILITY AND RELIABILITY

In order to widely adopt DC power systems for electric ships, new fault protection strategies are required, consisting of fault detection, protection device coordination, system reconfiguration, and fault isolation [79]. Since a DC zonal electric distribution system

is a promising candidate for surface combatant, the rationale for the DC zonal system was described in [80], along with the depiction of the stability issues, discussion of fault detection and load shedding problems. Since the use of MVDC power systems for AESs is commonly observed and a constant power load (CPL) behaviour may occur when large control bandwidths are employed for load converters, a destabilizing effect can be produced, which should be taken into consideration when analysing the system stability [58]. In [81], a control method based on linearization via state feedback (LSF) was proposed to solve the problem of CPL instability for multiconverter MVDC power systems on ships. A new comprehensive model was applied for analysing the multiconverter shipboard DC grid, and the overall behaviour in a second-order nonlinear differential equation was able to be captured. In the proposed method, the system nonlinearities were compensated by the LSF technique and then the traditional linear control techniques can be used for deriving a desired pole placement [81]. The original system model was simplified for the sake of providing a complete voltage control design procedure for DC radial grids. Apart from that, the shipboard plant requirements were to be met by considering the implementation aspects in the proposed control design. Moreover, the first medium-voltage impedance measurement unit (IMU) was designed and implemented in [82] to characterize in-situ source and load impedances of AC and DC networks in a specific frequency range, with the aim of assessing the system stability of ESs. A single-phase wide-bandwidth injection algorithm was employed for identifying small-signal dq impedances of MVAC and MVDC systems of ESs. Besides, the minimized hardware size, weight and complexity were obtained with the single-phase injection of perturbation current or voltage by using a modular SiC converter. The proposed IMU is applicable at several different low and medium voltage levels since the modularity and scalability are presented in the proposed injection converter solution. The simplified structure of the illustration displaying IMU insertion into the AES MVDC distribution system is shown in Fig. 10.

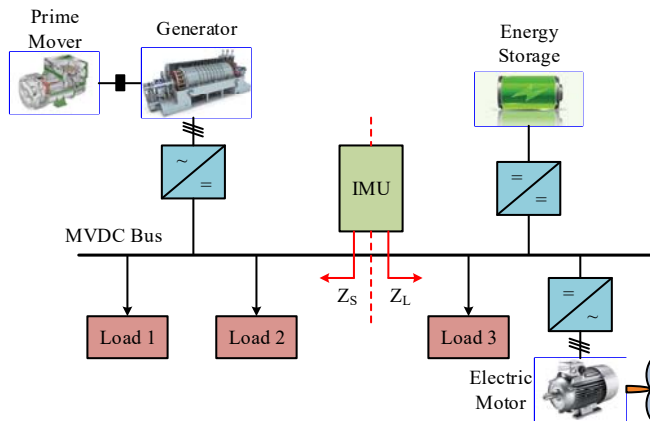

Fig. 10. Illustration showing IMU insertion into the AES MVDC distribution system (simplified) [82]

In terms of the ways of solving the issues of faults and failure of the components for ESs or AESs, it is possible to use intelligent reconfiguration of system function and connectivity, which is based on the system level knowledge of component failure when the intelligent power distribution is in the faulty modes [83]. The intelligent diagnostic requirements of future AES IPS were illustrated in [83], along with the introduction of emerging technologies that are available to be integrated into future ship IPSs. Particularly, for recent Navy ships, both survivability and affordability are required, where the crew intensive functions should be reallocated to intelligent automation. In [83], the opinion that diagnostic knowledge management should begin at the earliest stages of ship design and continue throughout the vessel's life was raised. In addition, the accuracy of embedded diagnostics is of importance for implementing advanced reconfigurable control algorithms. Some major types of IPS components which are taken into consideration in the diagnostic management strategies are illustrated in Fig. 11.

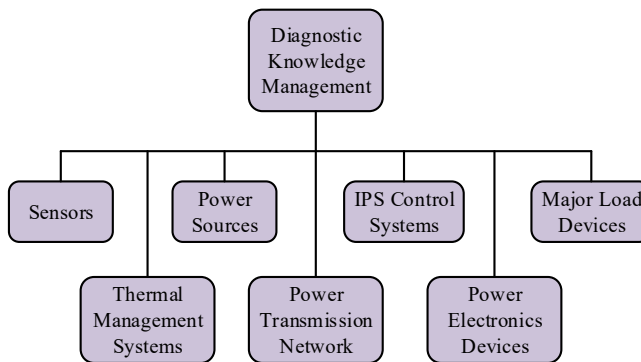

Fig. 11. Diagnostic knowledge management of IPS components [83]

From Figure 11, the following points can be summarized [83]: 1) a huge potential exists in the process of diagnostic development, 2) most of the diagnostic technologies are not demonstrated in real-world service, 3) the evolution of diagnostics in the whole lifecycle of the ship is inevitable, 4) further improvement in system reliability and affordability have to be achieved with upgrade mechanisms based on new diagnostic technologies. On top of that, the embedded diagnostic knowledge should be current and accurate.

In [84], a fast intelligent reconfiguration algorithm based on small-population-based particle swarm optimization (SPPSO) was proposed to maintain a proper power balance in the ship's power system when severe damages or faults are encountered during battle conditions for all-electric navy ships. The problem was first formulated as a single objective optimization one to obtain a fast execution speed for the algorithm, where the unique solution was derived directly with SPPSO. While in the cases that two conflicting objectives arise, the problem was formulated as a multi-objective one, where a set

of Pareto optimal solutions were extracted by SPPSO from two conflicting objectives. Then by passing the solutions through a number of questions that represent user preferences with respect to mission-specific requirements, the final solution can be obtained based on the response to those questions [84].

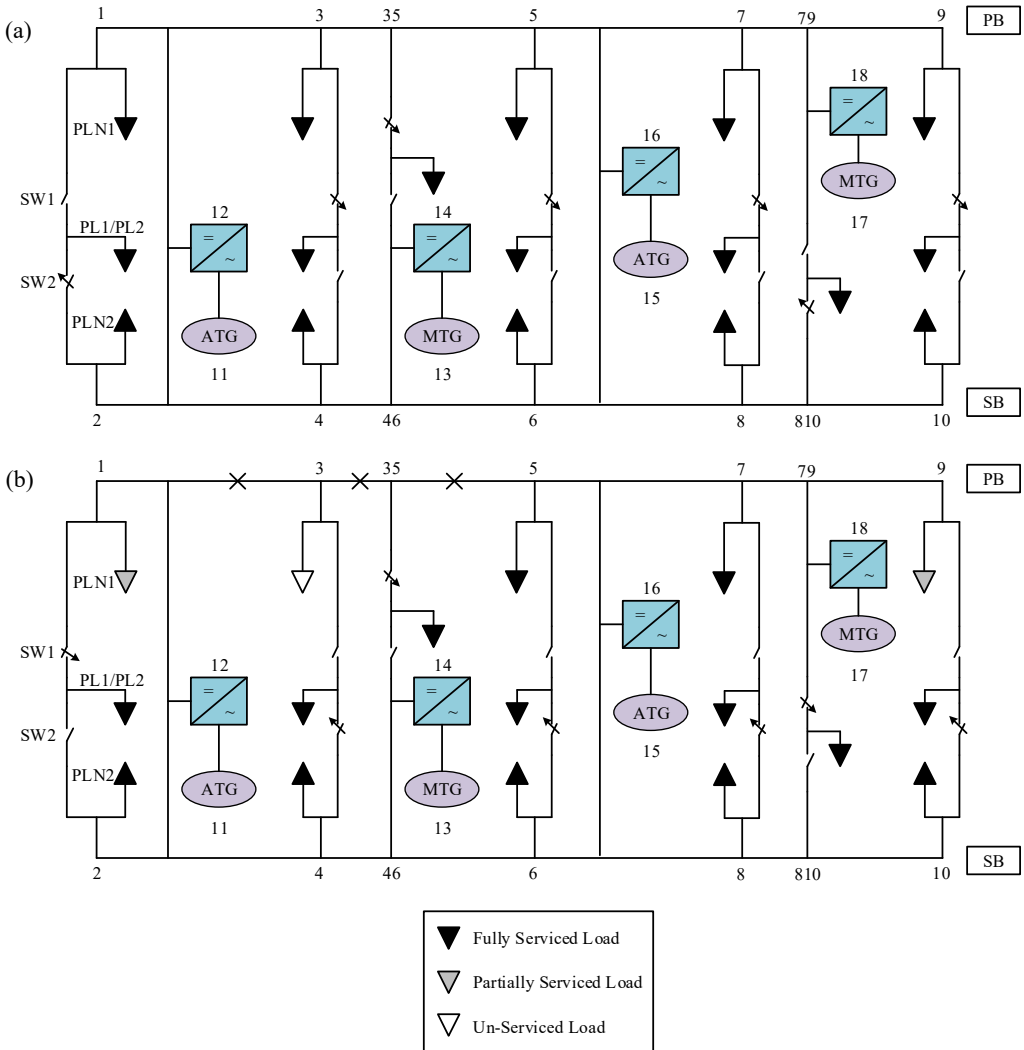

Fig. 12. Schematic views of SPS: a) under pre-fault condition, b) under faults occurring at 1-3, 3-35, and 35-5 [85]

The optimal reconfiguration of SPS was analysed in [85], and a new balanced hybrid (AC and DC) SPS was considered for optimizing the status of switches to maximize the power delivered to loads after the occurrence of a fault. In addition, the discussion on

the tradeoff between power delivered and number of switching operations at steady state was presented after reconfiguration. The traditional reconfiguration methods for terrestrial systems were usually regarded as an optimization problem by considering different types of objectives. However, these existing approaches typically require running a complete power flow algorithm after each switching step, which slows down the process and under certain situations they are not feasible. Therefore, by considering optimization of the objective function and satisfying the power flow constrains, better solutions can be proposed [85]. The methods proposed are with low complexity with the aid of a new MVDC ship model, and near-optimal solution can be derived within milliseconds. The schematic views of SPS under both the pre-fault and post-fault conditions are displayed in Fig. 12.

In the proposed method, two centralized optimization solutions were evaluated that deliver near-optimal power to loads in SPS. Compared with the global solver using “branch and bound” method, much lower complexity was presented in the proposed one. It was illustrated that the vital and semi-vital loads are serviced properly in 50% of the fault cases, where up to four random faults were included [85].

An active impedance estimation (AIE) scheme was proposed in [86] to accurately determine the fault location in a zonal DC marine power system (MPS). The injection of a short-duration disturbance onto the MPSs is required in the proposed method, and then the transient response measured at the point of coupling was utilized for determining the impedance of the power system. In addition, the effective operation of AIE in terms of identifying changes in bus impedance caused by short-circuit faults was demonstrated in a 30-kW experimental zonal DC distribution system. Moreover, the employment of the proposed technique in a DC MPS for obtaining more intelligent reconfigurations for faulty cases was discussed. The main advantage of the proposed fault location identification scheme is that system-wide communications are not needed, which creates the possibility for the equipment in each zone to accurately locate the faults and reconfigure the power system automatically. A MMC with hierarchical redundancy ability was designed and implemented for electric ship medium-voltage DC system in [34]. The proposed hierarchical redundant strategy was realized smoothly by the design of pretreatment units, which did not compromise the modulation and sort-and-selection strategies designed for normal condition. The fault detection circuit and mechanical switch for each submodule (SM) were suggested, and the faulty SM can be isolated very quickly. In addition, the MMC can still work properly with the “hot-reserved” SMs, and even when a number of SMs are in fault, the MMC can persist to work. Besides, the devices will not be damaged when the voltage and current overshoots occur during the fault and redundancy processes. The redundancy strategy can make the MMC recover to the safe operation condition effectively, and the satisfactory output voltage was ensured. Three arrangements are contained in the DC-AC MMC suitable for ES MVDC power system, where the top arm and the bot-

tom arm consist of each arrangement. The configuration suitable for MVDC ES application is displayed in Fig. 13.

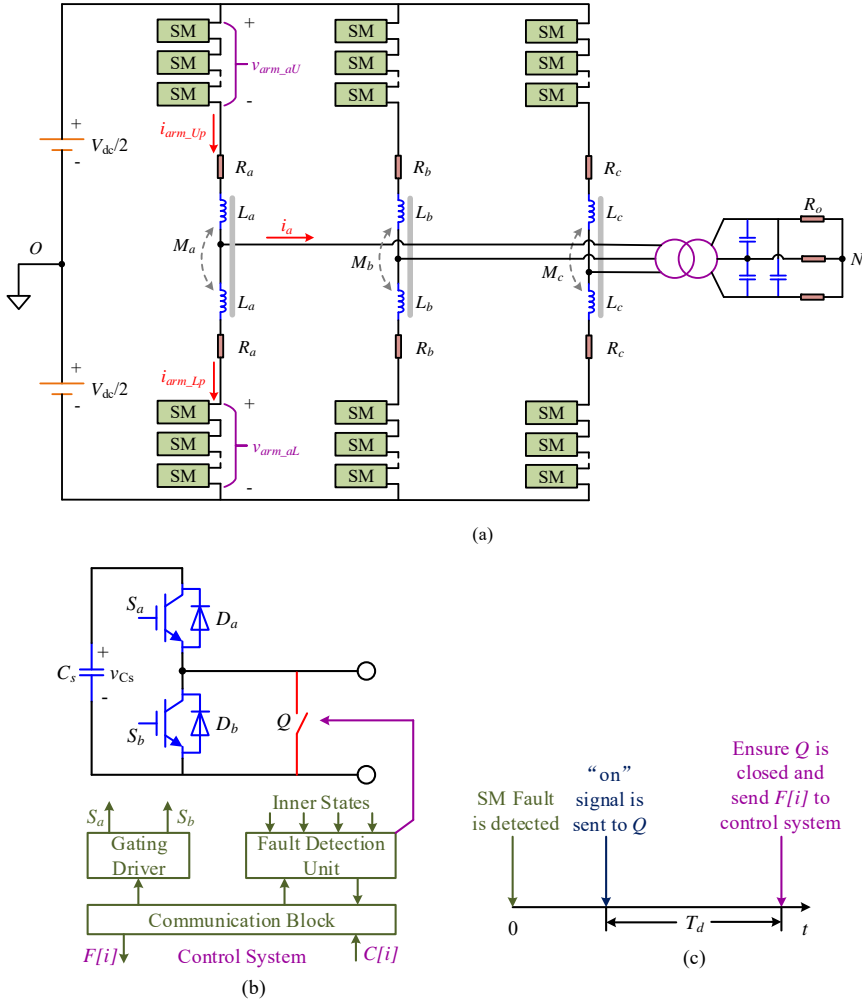

Fig. 13. Configuration of MMC suitable for MVDC application: a) topology of the MMC, b) SM with diagnosis unit, c) time sequence of the SM operation [34]

6. CONCLUSION

This paper gives a comprehensive overview of electric ships in terms of the design, control, power management, system stability and reliability. With the propose of meeting the increasing electricity demand and achieving flexible power delivery in ESS,

MVDC SPS is being widely used in various categories of vessels. With such a promising architecture, electric propulsion is likely to be completely realized for the next generation of merchant, cruise, and military ships. In addition, the rapid development of ES depends on the emergence of advanced power electronics techniques, where multilevel converters have been extensively investigated for large-scale microgrid applications. Besides, the hierarchical control scheme was proposed to integrate the smart grid and dc microgrid technologies into shipboard electrical networks to obtain different control functions. Furthermore, new fault protection strategies were presented to ensure shipboard DC power system stability and reliability.

REFERENCES

- [1] HANSEN J.F., WENDT F., *History and state of the art in commercial electric ship propulsion, integrated power systems, and future trends*, Proc. IEEE, 2015, 103(12), 2229–2242.
- [2] DNANES A.K.A., *Maritime electrical installations and diesel electric propulsion*, ABB report/Lecture note NTNU, 2003.
- [3] SKJONG E., VOLDEN R., RODSKAR E., MOLINAS M., JOHANSEN T.A., CUNNINGHAM J., *Past, Present, and future challenges of the marine vessel's electrical power system*, IEEE Trans. Transport. Electr., 2016, 2(4), 522–537.
- [4] SULLIGOI G., VICENZUTTI A., MENIS R., *All-electric ship design. from electrical propulsion to integrated electrical and electronic power systems*, IEEE Trans. Transport. Electr., 2016, 2(4), 507–521.
- [5] VICENZUTTI A., BOSICH D., GIADROSSI G., SULLIGOI G., *The role of voltage controls in modern all-electric ships. Toward the all electric ship*, IEEE Electr. Mag., 2015, 3(2), 49–65.
- [6] CHALFANT J., *Early-stage design for electric ship*, Proc. IEEE, 2015, 103(12), 2252–2266.
- [7] KEANE R.G. Jr., *Reducing total ownership cost. Designing inside-out of the hull*, Naval Eng. J., 2012, 124(4), 67–80.
- [8] THURKINS E.J. Jr., *Development of an early stage ship design tool for rapid modeling in paramarine*, Nav. E. thesis, Dept. Mech. Eng., Massachusetts Inst. Technology, Cambridge, MA, USA, 2012.
- [9] JURKIEWICZ D.J., CHALFANT J., CHRYSOSTOMIDIS C., *Modular IPS machinery arrangement in early-stage naval ship design*, Proc. 2013 IEEE Electric Ship Technology Symp. (ESTS), Arlington, VA, USA, 2013, 22–24.
- [10] NESTORAS K., *A tool to create hydrodynamically optimized hull-forms with geometrical constraints from internal arrangements*, S.M. thesis, Dept. of Mechanical Engineering, Massachusetts Institute of Technology, Cambridge, MA, USA, 2013.
- [11] OERS B.V., STAPERSMA D., HOPMAN J.J., *A 3D packing approach for the early stage configuration design of ships*, V. Bertram (Ed.), Proc. Int. Conf. Computer Applications and Information Technology in the Maritime Industries (COMPIT), Gubbio, Italy, 2010, 367–381.
- [12] DOERRY N.H., CLAYTON D.H., *Shipboard electrical power quality of service*, Proc. IEEE Electric Ship Technology Symp., Philadelphia, PA, USA, 2005, 274–279.
- [13] GALE P.A., *The ship design process*, [in:] T. Lamb (Ed.), *Ship design and construction*, Vol. 1, Alexandria, VA, USA, Society of Naval Architects and Marine Engineers, 2003, Ch. 5.
- [14] MISTREE F., SMITH W.F., BRAS B., ALLEN J.K., MUSTER D., *Decision based design. A contemporary paradigm for ship design*, Trans. Society of Naval Architects and Marine Engineers, 1990, 98, 565–597.
- [15] CHALFANT J., FERRANTE M., CHRYSOSTOMIDIS C., *Design of a notional ship for use in the development of early-stage design tools*, [in:] Proc. 2015 IEEE Electric Ship Technology Symposium (ESTS), Alexandria, VA, USA, June 22–24, 2015, 239–244.

- [16] BROWN A., SALCEDO J., *Multiple-objective optimization in naval ship design*, Naval Eng. J., 2003, 115(4), 49–61.
- [17] STEPANCHICK J., BROWN A., *Revisiting DDGX/DDG-51 concept exploration*, Naval Eng. J., 2007, 119(3), 67–88.
- [18] ALI H., DOUGAL R., OUROUA A., HEBNER R., STEURER M., ANDRUS M., LANGSTON J., SCHODER K., HOVSAPIAN R., *Cross-platform validation of notional baseline architecture models of naval electric ship power systems*, Proc. IEEE Electric Ship Technology Symp., ESTS, Alexandria, VA, USA, 2011, 78–83.
- [19] WANG Z., WANG X., CAO J., CHENG M., HU Y., *Direct torque control of T-NPC inverters-fed double-stator-winding PMSM drives with SVM*, IEEE Trans. Power Electron., 2018, 33(2), 1541–1553.
- [20] WU P.-H., CHEN Y.-T., CHENG P.-T., *The delta-connected cascaded H-bridge converter application in distributed energy resources and fault ride through capability analysis*, IEEE Trans. Ind. Appl., 2017, 53(5), 4665–4672.
- [21] JANKOVIC M., COSTABEBER A., WATSON A., CLARE J.C., *Arm-balancing control and experimental validation of a grid-connected MMC with pulsed DC load*, IEEE Trans. Ind. Electron., 2017, 64(12), 9180–9190.
- [22] QUAN Z., LI Y., *Harmonic analysis of interleaved voltage source converters and tri-carrier PWM strategies for three-level converters*, 18th Workshop on Control and Modeling for Power Electronics (COMPEL), IEEE, Stanford, CA, USA, 2017, 1–7.
- [23] LIU H., ZHANG D., WANG D., *Design considerations for output capacitance under inductance mismatches in multiphase buck converters*, IEEE Trans. Power Electron., 2017, 32(7), 5004–5015.
- [24] ARIFF E.A.R.E., DORDEVIC O., JONES M., *A space vector PWM technique for a three-level symmetrical six-phase drive*, IEEE Trans. Ind. Electron., 2017, 64(11), 8396–8405.
- [25] MA H., CHEN G., YI J.H., MENG Q.W., ZHANG L., XU J.P., *A single-stage PFM-APWM hybrid modulated soft-switched converter with low bus voltage for high-power LED lighting applications*, IEEE Trans. Ind. Electron., 2017, 64(7), 5777–5788.
- [26] ERICSEN T., HINGORANI N., KHERSONSKY Y., *PEBB – power electronics building blocks. From concept to reality*, Petroleum and Chemical Industry Conference, 2006, PCIC '06, Proc. IEEE Industry Applications Society 53rd Annual, Philadelphia, PA, USA, 2006, 12–16.
- [27] YU J., BURGOS R., MEHRABADI N.R., BOROYEVICH D., *DC fault current control of modular multilevel converter with SiC-based power electronics building blocks*, Electric Ship Technologies Symp., ESTS, IEEE, Arlington, VA, USA, 2017, 30–35.
- [28] WANG F., ZHANG Z., ERICSEN T., RAJU R., BURGOS R., BOROYEVICH D., *Advances in power conversion and drives for shipboard systems*, Proc. IEEE, 2015, 103(12), 2285–2311.
- [29] DEBNATH S., QIN J., BAHRANI B., SAEEDIFARD M., BARBOSA P., *Operation, control, and applications of the modular multilevel converter. A review*, IEEE Trans. Power Electron., 2015, 30(1), 37–53.
- [30] PEREZ M.A., BERNET S., RODRIGUEZ J., KOURO S., LIZANA R., *Circuit topologies, modeling, control schemes, and applications of modular multilevel converters*, IEEE Trans. Power Electron., 2015, 30(1), 4–17.
- [31] CUZNER R.M., SOMAN R., STEURER M.M., TOSHON T.A., FARUQUE M.O., *Approach to scalable model development for navy shipboard compatible modular multilevel converters*, IEEE J. Emerg. Sel. Topics Power Electron., 2017, 5(1), 28–39.
- [32] MO R., LI H., *Hybrid energy storage system with active filter function for shipboard MVDC system applications based on isolated modular multilevel DC/DC converter*, IEEE J. Emerg. Sel. Topics Power Electron., 2017, 5(1), 79–87.
- [33] CHEN Y., ZHAO S., LI Z., WEI X., KANG Y., *Modeling and control of the isolated DC-DC modular multilevel converter for electric ship medium voltage direct current power system*, IEEE J. Emerg. Sel. Topics Power Electron., 2017, 5(1), 124–139.

- [34] CHEN Y., LI Z., ZHAO S., WEI X., KANG Y., *Design and implementation of a modular multilevel converter with hierarchical redundancy ability for electric ship MVDC system*, IEEE J. Emerg. Sel. Topics Power Electron., 2017, 5(1), 189–202.
- [35] MILLAN J., GODIGNON P., PERPINA X., PEREZ-TOMAS A., REBOLLO J., *A survey of wide bandgap power semiconductor devices*, IEEE Trans. Power Electron., 2014, 29(5), 2155–2163.
- [36] BIELA J., SCHWEIZER M., WAFFLER S., KOLAR J.W., *SiC versus Si. Evaluation of potentials for performance improvement of inverter and DC-DC converter systems by SiC power semiconductors*, IEEE Trans. Ind. Electron., 2011, 58(7), 2872–2882.
- [37] MISHRA U.K., PARIKH P., WU Y.-F., *AlGaN/GaN HEMTs – an overview of device operation and applications*, Proc. IEEE, 2002, 90(6), 1022–1031.
- [38] BAGINSKI T.A., THOMAS K.A., *A robust one-shot switch for high power pulse applications*, IEEE Trans. Power Electron., 2009, 24(1), 253–259.
- [39] MITRA P., VENAYAGAMOORTHY G.K., *An adaptive control strategy for DSTATCOM applications in an electric ship power system*, IEEE Trans. Power Electron., 2010, 25(1), 95–104.
- [40] KANELLOS F.D., ANVARI-MOGHADDAM A., GUERRERO J.M., *A cost-effective and emission-aware power management system for ships with integrated full electric propulsion*, Electric Power Syst. Res., 2017, 150, 63–75.
- [41] SKJONG E., SUUL J.A., RYGG A., JOHANSEN T.A., MOLINAS M., *System-wide harmonic mitigation in a diesel-electric ship by model predictive control*, IEEE Trans. Ind. Electron., 2016, 63(7), 4008–4019.
- [42] IM W.-S., WANG C., TAN L., LIU W., LIU L., *Cooperative controls for pulsed power load accommodation in a shipboard power system*, IEEE Trans. Power Syst., 2016, 31(6), 5181–5189.
- [43] DONG D., PAN Y., LAI R., WU X., WEEBER K., *Active fault-current foldback control in thyristor rectifier for DC shipboard electrical system*, IEEE J. Emerg. Sel. Topics Power Electron., 5(1), 203–212, 2017.
- [44] YAN C., VENAYAGAMOORTHY G.K., CORZINE K., *Hardware implementation of an AIS-based optimal excitation controller for an electric ship*, IEEE Trans. Ind. Appl., 2011, 47(2), 1060–1070.
- [45] VALLE Y.D., VENAYAGAMOORTHY G.K., MOHAGHEGHI S., HERNANDEZ J.C., HARLEY R.G., *Particle swarm optimization. Basic concepts, variants and applications in power systems*, IEEE Trans. E, Comput., 2008, 12(2), 171–195.
- [46] YAN C., VENAYAGAMOORTHY G.K., CORZINE K., *AIS-based coordinated and adaptive control of generator excitation systems for an electric ship*, IEEE Trans. Ind. Electron., 2012, 59(8), 3102–3112.
- [47] ZHENG F., WANG Q., LEE T.H., HUANG X., *Robust PI controller design for nonlinear systems via fuzzy modeling approach*, IEEE Trans. Syst., Man, Cybern. A, Syst., Humans, 2001, 31(6), 666–675.
- [48] KARIMI A., FELIACHI A., *PSO-tuned adaptive backstepping control of power systems*, Proc. IEEE Power Systems Conf. Expo., 2006, 1315–1320.
- [49] MOHAGHEGHI S., VALLE Y.D., VENAYAGAMOORTHY G.K., HARLEY R.G., *A proportional-integrator type adaptive critic design-based neurocontroller for a static compensator in multimachine power systems*, IEEE Trans. Ind. Electron., 54(1), 86–96, 2007.
- [50] KANKANALA P., SRIVASTAVA S.C., SRIVASTAVA A.K., SCHULZ N.N., *Optimal control of voltage and power in a multi-zonal MVDC shipboard power system*, IEEE Trans. Power Syst., 2012, 27(2), 642–650.
- [51] MASHAYEKH S., BUTLER-PURRY K.L., *An integrated security-constrained model-based dynamic power management approach for isolated microgrids in all-electric ships*, IEEE Trans. Power Syst., 2015, 30(6), 2934–2945.
- [52] TASHAKORI ABKENAR A., NAZARI A., JAYASINGHE S.D.G., KAPOOR A., NEGNEVITSKY M., *Fuel cell power management using genetic expression programming in all-electric ships*, IEEE Trans. En. Conv., 2017, 32(2), 779–787.

- [53] SHARIATZADEH F., KUMAR N., SRIVASTAVA A.K., *Optimal control algorithms for reconfiguration of shipboard microgrid distribution system using intelligent techniques*, IEEE Trans. Ind. Appl., 2017, 53(1), 474–482.
- [54] JIN Z., SULLIGOI G., CUZNER R., MENG L., VASQUEZ J.C., GUERRERO J.M., *Next-generation shipboard DC power system. Introduction smart grid and DC microgrid technologies into maritime electrical networks*, IEEE Electr. Mag., 2016, 4(2), 45–57.
- [55] RUDRARAJU S.R., SRIVASTAVA A.K., SRIVASTAVA S.C., SCHULZ N.N., *Small signal stability analysis of a shipboard MVDC power system*, Proc. IEEE Electric Ship Technology Symp., 2009, 135–141.
- [56] LIU X., LI H., WANG Z., *A start-up scheme for a three-stage solid-state transformer with minimized transformer current response*, IEEE Trans. Power Electron., 2012, 27(12), 4832–4836.
- [57] XU S., HUANG A.Q., BURGOS R., *Review of solid-state transformer technologies and their application in power distribution systems*, IEEE J. Emerg. Sel. Topics Power Electron., 2013, 1(3), 186–198.
- [58] KHAN M.M.S., FARUQUE M.O., *Energy storage management for MVDC power system of all electric ship under different load conditions*, Electric Ship Technologies Symposium (ESTS), 2017 IEEE, Arlington, VA, USA, 2017, 192–199.
- [59] PETERSEN L.J., HOFFMAN D.J., BORRACCINI J.P., SWINDLER S.B., *Next generation power and energy. Maybe not so next generation*, J. Naval Eng., 2010, 122(4), 59–74.
- [60] DOERRY N., AMY J., *MVDC shipboard power system considerations for electromagnetic railguns*, Proc. 6th DoD Electromagnetic Railgun Workshop, Laurel, MD, USA, 2015, 15–16.
- [61] MCCOY T.J., *Integrated power systems. An outline of requirements and functionalities for ships*, Proc. IEEE, 2015, 103(12), 2276–2284.
- [62] SULLIGOI G., TESSAROLO A., BENUCCI V., MILLERANI-TRAPANI A., BARET M., LUISE F., *Shipboard power generation. Design and development of a medium-voltage DC generation system*, IEEE Ind. Appl. Magazine, 2013, 19(4), 47–55.
- [63] KANELLOS F.D., PROUSALIDIS J., TSEKOURAS G.J., *Onboard DC grid employing smart grid technology. Challenges, state of the art and future prospects*, IET Electr. Syst. Transport., 2015, 5(1), 1–11.
- [64] IEEE recommended practice for 1 to 35 kV medium voltage DC power systems on ships, IEEE Standards Association, 2010, <https://standards.ieee.org/findstds/standard/1709-2010.html>
- [65] FARASAT M., ARABALI A., TRZYNADLOWSKI A.M., *Flexible-voltage DC-bus operation for reduction of switching losses in all-electric ship power systems*, IEEE Trans. Power Electron., 2014, 29(11), 6151–6161.
- [66] SU C.-L., LIN K.-L., CHEN C.-J., *Power flow and generator-converter schemes studies in ship MVDC distribution systems*, IEEE Trans. Ind. Appl., 2016, 52(1), 50–59.
- [67] SEENUMANI G., SUN J., PENG H., *Real-time power management of integrated power systems in all electric ships leveraging multi time scale property*, IEEE Trans. Control Syst. Technology, 2011, 232–240.
- [68] SEENUMANI G., SUN J., PENG H., *A numerically efficient iterative procedure for hybrid power system optimization using sensitivity functions*, Proc. American Control Conf., 2007, 4738–4743.
- [69] FENG X., BUTLER-PURRY K.L., ZOURNTOS T., *Multi-agent system-based real-time load management for all-electric ship power systems in DC zone level*, IEEE Trans. Power Syst., 2012, 27(4), 1719–1728.
- [70] FENG X., BUTLER-PURRY K.L., ZOURNTOS T., *A Multi-agent system framework for real-time electric load management in MVAC all-electric ship power systems*, IEEE Trans. Power Syst., 2015, 30(3), 1327–1336.
- [71] KANELLOS F.D., *Optimal power management with GHG emissions limitation in all-electric ship power systems comprising energy storage systems*, IEEE Trans. Power Syst., 2014, 29(1), 330–339.
- [72] KANELLOS F.D., TSEKOURAS G.J., HATZIARGYRIOU N.D., *Optimal demand-side management and power generation scheduling in an all-electric ship*, IEEE Trans. Sust. En., 2014, 5(4), 1166–1175.
- [73] JOHANSEN T.A., BO T.I., MATHIESEN E., VEKSLER A., SORENSEN A.J., *Dynamic positioning system as dynamic energy storage on diesel-electric ships*, IEEE Trans. Power Syst., 2014, 29(6), 3086–3091.

-
- [74] MASAUD T.M., LEE K., SEN P.K., *An overview of energy storage technologies in electric power systems: What is the future?*, North American Power Symp. (NAPS), Arlington, TX, USA, 2010, 1–6.
- [75] SU C.-L., WENG X.-T., CHEN C.-J., *Power generation controls of fuel cell/energy storage hybrid ship power systems*, Transport. Electr. Asia-Pacific (ITEC Asia-Pacific), 2014 IEEE Conference and Expo, Beijing, China, 2014, 1–6.
- [76] KHAN M.M.S., FARUQUE M.O., NEWAZ A., *Fuzzy logic based energy storage management system for MVDC power system of all electric ship*, IEEE Trans. En. Conv., 2017, 32(2), 798–809.
- [77] SCIBERRAS E.A., ZAHAWI B., ATKINSON D.J., BREIJS A., VAN VUGT J.H., *Managing shipboard energy. A stochastic approach special issue on marine systems electrification*, IEEE Trans. Trans. Electr., 2016, 2(4), 538–546.
- [78] BANAEI M.R., ALIZADEH R., *Simulation-based modeling and power management of all-electric ships based on renewable energy generation using model predictive control strategy*, IEEE Int. Trans. Syst. Mag., 2016, 8(2), 90–103.
- [79] CAIROLI P., DOUGAL R.A., *New horizons in DC shipboard power systems. New fault protection strategies are essential to the adoption of DC power systems*, IEEE Electr. Mag., 2013, 1(2), 38–45.
- [80] CIEZKI J.G., ASHTON R.W., *Selection and stability issues associated with a navy shipboard DC zonal electric distribution system*, IEEE Trans. Power Del., 2000, 15(2), 665–669.
- [81] SULLIGOI G., BOSICH D., GIADROSSI G., ZHU L., CUPELLI M., MONTI A., *Multiconverter medium voltage DC power systems on ships. Constant-power loads instability solution using linearization via state feedback control*, IEEE Trans. Smart Grid, 2014, 5(5), 2543–2552.
- [82] JAKŠIĆ M., SHEN Z., CVETKOVIĆ I., BOROYEVICH D., BURGOS R., DIMARINO C., CHEN F., *Medium-voltage impedance measurement unit for assessing the system stability of electric ships*, IEEE Trans. En. Conv., 2017, 32(2), 829–841.
- [83] LOGAN K.P., *Intelligent diagnostic requirements of future all-electric ship integrated power system*, IEEE Trans. Ind. Appl., 2007, 43(1), 139–149.
- [84] MITRA P., VENAYAGAMOORTHY G.K., *Implementation of an intelligent reconfiguration algorithm for an electric ships power system*, IEEE Trans. Ind. Appl., 2011, 47(5), 2292–2300.
- [85] BOSE S., PAL S., NATARAJAN B., SCOGLIO C.M., DAS S., SCHULZ N.N., *Analysis of optimal reconfiguration of shipboard power systems*, IEEE Trans. Power Syst., 2012, 27(1), 189–197.
- [86] CHRISTOPHER E., SUMNER M., THOMAS D.W.P., WANG X., DE WILDT F., *Fault location in a zonal DC marine power system using active impedance estimation*, IEEE Trans. Ind. Appl., 2013, 49(2), 860–865.